

# Dräger



ST-10002-2008

## Introduction to personal protection technology

Dräger. Technology for Life®

## When does air become dangerous?

The normal atmosphere is only made up of about 21 % O<sub>2</sub>. If the breathing air does not have enough oxygen, it can be life-threatening. Especially dangerous: You cannot detect a lack of oxygen with your nose.

Our atmosphere is composed as follows (in ppm):

Gas		Composition	
		dry	humid
Main gases	N <sub>2</sub> – Nitrogen	780,840	768,543
	O <sub>2</sub> – Oxygen	209,450	206,152
	H <sub>2</sub> O – Water vapor	0	15 748
	Ar – Argon	9,340	9,193
	CO <sub>2</sub> – Carbon Dioxide	340	335
Trace gases			

### How does a lack of oxygen come about?

When inert gas flows into the atmosphere, it displaces the oxygen. Since roughly only one-fifth of the atmosphere is oxygen, the oxygen concentration is only reduced by one-fifth of the concentration of inert gas.

#### Danger of inertization

Industrial firms mainly use liquid nitrogen (- 196 °C). If it evaporates this can rapidly lead to a lack of oxygen. If nitrogen in the ambient air reaches 10%, the concentration of oxygen decreases by 2%.

Lack of oxygen causes the following symptoms:

oxygen-concentration in vol %	oxygen-partial pressure in hPa	Symptoms
< 17	< 170	tendency towards danger from lack of oxygen
11 to 14	110 to 140	unnoticeable reduction in physical and mental capabilities
8 to 11	80 to 110	possibility of unconsciousness without warning after a certain period of time
6 to 8	60 to 80	unconsciousness in a few minutes (resuscitation possible if initiated immediately)
< 6	< 60	immediate loss of consciousness



ST-9701-2008

## What are contaminants?

In general terms, contaminants means substances or mixtures of substances which are harmful to people, animals, plants, organisms, and whole ecosystems. According to the German Ordinance on Hazardous Substances, it is not only pure substances that are classed as contaminants, but also mixtures, preparations or products.

In principle, contaminants can be divided into two groups:

- natural  
(e.g. hydrogen cyanide in bitter almonds, mineral dust)
- synthetic, which have been created by man  
(e.g. vehicle exhaust gases, industrial fumes)

**When do contaminants become dangerous?**

If you get contaminants in your body they can cause illness. How the contaminants work depends on their respective characteristics and their interaction with the human body.

### **GAS MEASUREMENT AND WARNING DEVICES FROM DRÄGER**

In order to simply and rapidly detect dangers from flammable and toxic gases, Dräger offers a wide selection of gas measurement and warning devices for the widest range of uses.

You can find more detailed information in the Dräger brochure ›Introduction to portable gas measurement technology‹ (order number German: 90 46 554, English: 90 46 736) and on the Dräger website. Or you can simply ask your local Dräger representative.



D-3804-2010

## How do contaminants get into the body?

Contaminants can enter the body in three different ways:

- inhalation: via the respiratory tracts
- orally: through the mouth (mostly when swallowing)
- dermally: via the skin

How can a risk be recognized?

The ›Globally Harmonized System of Classification and Labeling of Chemicals‹ (GHS) internationally prescribes hazard communications elements for the uniform identification of hazardous substances, mixtures and products.

Examples of pictograms:



Acute toxicity



Corrosive/irritant

How do contaminants work?

Roughly speaking, three chronological impact categories can be differentiated:

- Hyper-acute → leads to death in a relatively short time
- Acute → works rapidly (e.g. poisoning, cauterization, irritation, burns after explosions)
- Chronic → longer duration of effect, which leads to chronic genetic changes (tumors, deformities) or to long-term poisoning with damage to organs (liver, lungs, kidney)



ST-2596-2004

## How can I protect myself from unclean air?

Are you sure that air in a certain workplace or working area is free of hazardous substances? Before you get to work, you should undertake a risk analysis to identify the risks and stresses for you and your employees. You can only effectively protect yourself from hazardous substances when you know which substances you are dealing with.

### Can I protect myself from hazardous substances in the workplace without respiratory equipment?

To limit the risk from hazardous substances you can take the following precautions:

- Replace hazardous substances with less dangerous substances (substitution)
- Avoid the hazardous substances being released by exhaust air, ventilation technology or encapsulation.
- Eliminate intake of hazardous substances by organizational measures

What if these measures are ineffective? Or if they can't be implemented? Or if you are not entirely certain that there is no danger left in the air? Then you should definitely take extra safety precautions, such as respiratory or body protection.

#### **Employee safety is obligatory**

Employers are duty bound to ensure that ambient air, in which employees work, contains sufficient oxygen. In addition, the employer must ensure that the employee's health is not damaged by contaminants. In Germany the threshold limit values (AGW) provided by the Committee on Hazardous Substances (AGS) apply. For other countries local limits apply.



## Is a filter device sufficient to protect against hazardous substances in the workplace?

That depends on the ambient air and conditions at your workplace. A filter device only offers sufficient protection when certain preconditions exist. If these do not exist, you have to take recourse to closed-circuit or open-circuit respiratory protection.

### Filter devices may be sufficient when:

- Oxygen content in ambient air is: min. 17 vol %  
(with CO filters: min 19 vol %)
- The type of hazardous substance is known, and there is a filter material for it
- The concentration of the hazardous substance is within the permitted limits for the application of filter devices

### Filter devices are not sufficient when:

- There is a risk that the hazard may change (e.g. poorly ventilated container, tanks, tunnels, ships)
- The hazardous substances have low warning characteristics (smell, taste)
- The concentrations of hazardous substances are immediately dangerous to life or well-being
- The hazardous substance is not retained by the filter material

### Which protection do I need for which hazardous substance?

Hazardous substance (absorbed via the respiratory tract)	Protection
Dust and smoke	Particle filter
Gases and vapors	Gas filters + masks
Particles + gases + vapors	Combination filters and masks
Lack of oxygen and/or too high concentration of hazardous substances	Closed-circuit or open-circuit respiratory protection

### MASKS AND FILTERS BY DRÄGER

You can find out more about masks and filters in the Dräger brochure ›A mask for all occasions‹ (order number German: 90 46 531, English: 90 46 532) and on the Dräger website. Or you can simply ask your local Dräger representative.

# Generating external breathing air



ST-564-2004

## This air is pure

Is the concentration of hazardous substances at your workplace too high and/or the oxygen content too low to protect your employees with filtering respiratory protection? Then you have to take recourse to open-circuit respiratory protection.

External air can be provided in two different ways:

- from a compressed air supply: directly via a compressor or compressed air network (pressure range 7 to 10 bar)
- from compressed air cylinders (nominal filling pressure max 300 bar)

## How will the breathing air be extracted for open-circuit respiratory protection?

Using compressors (mobile or stationary), external air is compressed for the direct compressed air supply or to fill the compressed air cylinder. Separators and filters in the compressor ensure that the air is cleaned.

## Compressor design

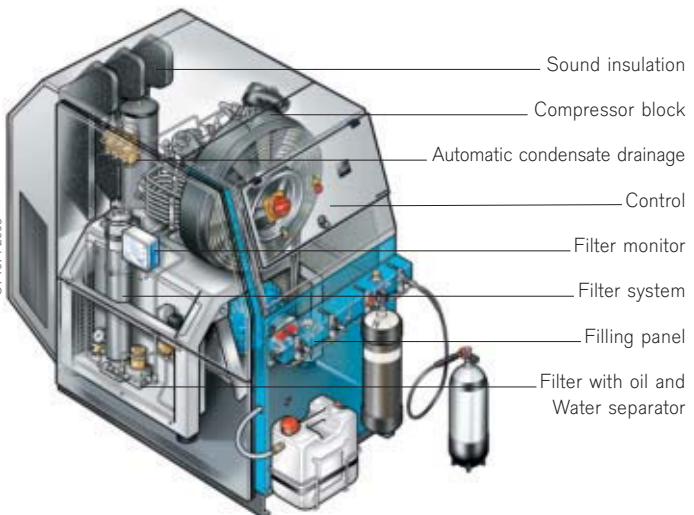

ST-1074-2008

# Generating external breathing air



## How can I guarantee the quality of external breathing air?

Whether exhaust gases and water in external air or lubricants from the compressor: When creating breathing air, you can never completely remove all impurities. For the quality of the breathing air to comply with the requirements of EN 12021, you must check it every 6 months in accordance with BGR 190. This does not just depend on the accuracy of the methods. The detection limits of the methods must also be within the required permitted values.

### Limiting values for impurities of external breathing air according to EN 12021:

- Lubricants (droplets or mist): 0.5 mg/m<sup>3</sup>
- Carbon dioxide content: 500 ppm
- Carbon monoxide content: 15 ppm
- Water content\*:  
50 mg/m<sup>3</sup> (at a nominal pressure of 40 to 200 bar) or  
35 mg/m<sup>3</sup> (at a nominal pressure greater than 200 bar)

(European reference condition: 1 bar absolute, 20 °C – Published 2010)

\* The current draft of EN 12021 (issued July 2010) specifies various max. allowable values for water content for the low pressure range of 5 to 30 bar.

## How can I ensure that external breathing air is pure?

### Compliance with limiting values for carbon monoxide, carbon dioxide and water:

With established Dräger tubes you have a simple test system on hand – both for low and high pressure areas. By this means you can quickly and comfortably check, on site, whether the max. allowable values are complied with.

### Compliance with max. allowable values for lubricants:

You can check if max. allowable values are complied with for lubricants using the Dräger Impactor. By this means you can measure synthetic oils, regardless of their kind and viscosity.



## This is a voice you can trust

With the increasing technological orientation of our society, the number of different hazardous substances and therefore the risk to humans also increases – in the environment and also at work. But what are the right protective measures that your company needs to take and for which hazardous substance? Dräger VOICE provides you with the comprehensive information you need for your safety. Quick, comprehensive and accessible at any time.

### What is VOICE?

VOICE is a comprehensive online database of constantly updated information on more than 1,700 hazardous substances and 11,500 synonyms. Within seconds, it makes a link between hazardous substance, measuring options and protective equipment. For added security, you also get advice on how to handle the recommended equipment properly.

### VOICE ONLINE

The hazardous substance database can be found on the Dräger website at [www.draeger.com/voice](http://www.draeger.com/voice)

# How does VOICE work?



ST-11190-2008

## What information can I find in VOICE?

Example: Search for benzene

Simply enter the substance in the search field:

**Substance Search**  
Search Criteria:

For each substance you have chosen, you will receive:

- Current national and international max allowable values
- Chemical and physical information (such as formula, vapor pressure, melting and boiling points)
- Fire prevention information (such as LEL, UEL, flash point, ignition point)
- Identification numbers (e.g. CAS No., UN No., EC No.)

**Benzene (Benzene)** [Chemical formula:  $C_6H_6$ ]

CAS-No.:	71-43-2	• other limits:
EINECS-No.:	200-753-7	
UN-No.:	1114	
• Fire Protection	• Marking	• Synonyms

## MEASUREMENT AND PERSONAL PROTECTION TECHNOLOGY FROM DRÄGER

In addition to substance-specific information, in VOICE you will also find recommendations for measurement and personal protection technology that you can order from Dräger.



• **Portable Gas Detection**



• **Air purifying respirators**



• **Body Protection**

All information in this brochure has been compiled to the best of our knowledge. This brochure does not represent any obligation or warranty. The information and data given in this brochure are subject to technical revisions and may not always correspond to the current situation. The instructions for use supplied with the products shall apply exclusively for the use of Dräger products. These are to be read and observed as carefully as possible before the application of such products.

## External air supply



D-10206-2010

## System overview



SI-11289-2008

## What are the requirements for chemical protective suits?

Mechanically chemical protective suits for example must be abrasion-proof, tear-resistant and puncture-resistant. Chemically, they must have a resistance against the penetration of hazardous substances.

### Performance types of chemical protective suits:

Depending on the resistance, chemical protective suits can be classified into different performance types. They are subjected to rigorous testing.

Type 1: Gas-tight	Type 1a	Compressed air breathing apparatus worn on the inside
	Type 1b	Compressed air breathing apparatus worn on the outside
	Type 1c	Breathing air supply through a compressed air hose system
Type 2: Not gas-tight		Breathing air supply through a compressed air hose system
Type 3: Liquid-proof		
Type 4: Spray-proof		
Type 5: Particle protection		
Type 6: Limited spray-proof		

### What standard applies to chemical protective suits?

For chemical protective suits – depending on the performance type – different levels of requirements apply. They are set out in the following standards:

- EN 943-1: Type 1a, 1b, 1c and 2
- EN 943-2: Type 1a ET and Type 1b ET (for emergency rescue teams)
- EN 14605: Type 3 and 4
- EN ISO13 982-1:2005: Type 5
- EN 13 034:2005: Type 6

### Is disposable protective clothing subject to the same high standards as reusable protective clothing?

No. The standard distinguishes between these two forms.

Mechanical resistance and flame resistance must be significantly higher for reusable protective suits.



## What makes a good protective material?

As a rule of thumb: The longer a chemical needs to penetrate a material the more effective the chemical protection of the material. Therefore, resistance to permeation is an important criterion according to EN 943-1 and EN 943-2.

### Penetration time: a measure of security

To find out how long a material can withstand the penetration of a particular chemical, the penetration time is measured: How long does it take for a certain concentration of the chemical to penetrate from the outside in? This penetration time is one of the most important core values for the operating time of a chemical protection suit.

In accordance with DIN EN ISO 6529 test procedures, chemical protection suits are divided into six classes depending on their penetration time:

Suit class	Penetration time	Suit class	Penetration time
1	> 10 min	4	> 120 min
2	> 30 min	5	> 240 min
3	> 60 min	6	> 480 min

### How can I ensure that my chemical suit can withstand a certain hazardous material?

Before use always check whether the selected suit has sufficient resistance against the particular hazardous substance. The manufacturer's resistance list will give the required information. The test requirements, which the resistance list data are based on, are significantly stricter than conditions in the workplace.











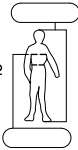

ST-11256-2008

## What information does the labeling on a chemical protective suit provide?

Amongst other things, the identification plate inside the suit provides information about:

- Manufacturer, trade name
- Classification
- Suit size
- Types of performance and the corresponding EN standards
- Operating and maintenance instructions
- Additional certification

Example of a label:

<b>SPC 3800 or</b>	
Splash Protective Clothing	
Part Number/Sachnummer:	
Dräger Safety AG & Co. KGaA	
TYCHEM F	DATE: 08/2008
Protective Clothing Category III	
<b>CE 0516</b>	
Type 3B: EN 14126:2003	EN 1073-2
Type 3: EN 14605:2005	
Type 4: EN 14605:2005	
Type 5: EN ISO 13982-1:2005	EN 14126
Type 6: EN 13034:2005	Size/Größe
<b>SOLAS Approval</b>	
EN 1149-1:1995 (Innenseite)	
	
	
     <b>stay away from flames</b>	

The symbols have the following meanings:

-  Clothing for protection against radioactive contamination.
-  Clothing for protection against infectious agents.
-  Protection against electrostatic charge in accordance with EN 1149-1:1995
-  Clothing for protection against chemicals.
-  Attention! Follow the instructions for use.
-  Do not wash!
-  Do not bleach!
-  Do not iron!
-  Do not tumble dry!
-  Do not dry clean!
-  stay away from flames Avoid open flames!

## Gas-tight materials (Type 1)

### D-MEX –

#### Maximum protection even under severe conditions

- Reusable
- Mechanically extremely strong and resilient yet lightweight and flexible
- The highest penetration times against industrial chemicals, warfare agents, etc.
- Does not become brittle in contact with supercooled materials
- Flame retardant and self-extinguishing even in open flames

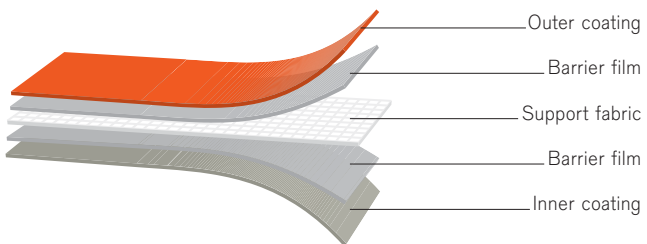

### Himex –

#### High level of protection for demanding tasks

- Reusable
- Mechanically highly resilient
- High penetration times, for example, for industrial chemicals
- Flame retardant and self-extinguishing

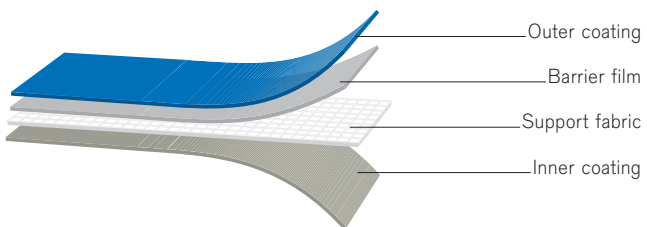

## Gas-tight materials (Type 1)

Symex –

Good resistance to acids, alkalis and oils

- Reusable
- Lightweight material
- Highly flexible and resistant to abrasion

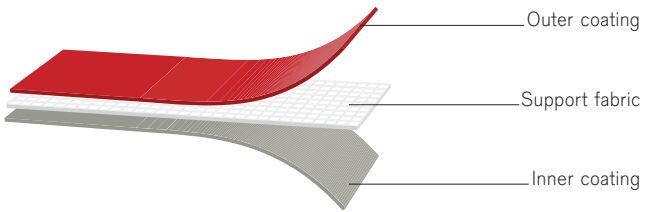

Umex –

Particularly suitable when working with chlorine and ammonia

- Reusable
- Lightweight and soft material
- Does not become brittle in contact with supercooled materials

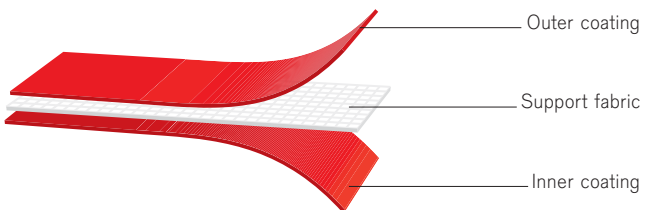

ZYTRON 500 –

High level of protection against various hazardous goods

- Disposable material for work with low mechanical stress
- High level of daily comfort, as flexible and very light
- High penetration times for industrial chemicals and warfare agents

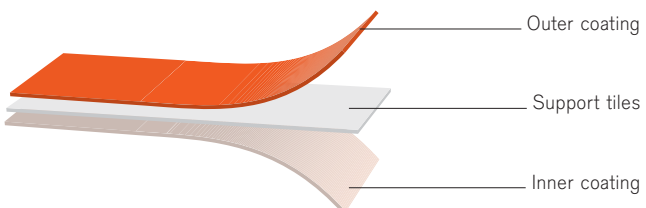

## Liquid-proof materials (Type 3)

### Tychem F –

**Ideal for handling liquids and solids**

- Disposable material for work with low mechanical stress
- Good protection against organic and highly concentrated inorganic hazardous substances
- Particularly low weight



### Tychem C –

**Ideal for use with infectious agents and acids**

- Disposable material for work with low mechanical stress
- Particularly low weight

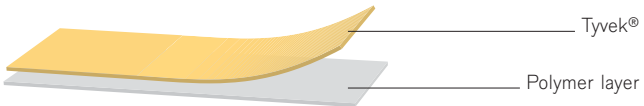

### PVC –

**Good protection against low concentrations of acids and alkalis**

- Reusable
- Highly flexible and resistant to tears
- Liquid tight even in strong liquid jets (e.g. pressure washer)

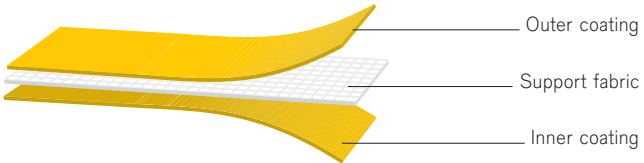

## Spray-tight materials (Type 4)

### Flexothane –

**Good level of protection against crude oil, machine oil, kerosene, paint and dust**

- Reusable
- Lightweight and flexible
- Water vapor permeable

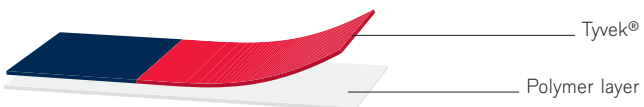



ST-10071-2008

## What accessories do I need for a chemical protective suit?

### Boots and gloves

Protective boots and gloves are necessary for the handling hazardous materials. If they are not integrated into the suit, you should look for the following points when making your choice:

- Appropriate safety class for dealing with the particular chemical
- Easy to put on and remove

### USEFUL INFORMATION

For hygienic reasons it is advisable to wear cotton gloves.

Over-gloves protect the actual protective glove from mechanical influences.

### Ventilation systems

Using a suit is heavy physical work. Temperature and humidity rise quickly inside the suit. This increases the risk of heart and circulatory failure. To lower the temperature in the suit, some suits have ventilation systems. That means: humid, warm air is extracted from the suit via a pressure relief valve. The fresh air flow from the external air supply accelerates evaporation and provides a pleasant cooling effect.

### Comfort vest

Reusable cooling elements that you insert into a comfort vest can give you real relief, especially during longer missions. They reduce skin temperature by 3 to 4° C – for one and a half to two hours.



SI-10043-2008

### After use is before use

In order to be able to rely fully on your protective suit the next time you use it, after each use you must thoroughly clean it, maintain it and, where necessary, repair and inspect it. There are different cleaning methods depending on the degree of contamination.

#### Contamination can take different forms:

- Dust and particles remain adhered to the surface of the suit  
→ Adhesion
- Liquids or gases and vapors are absorbed by the clothing material  
→ Absorption
- Liquids are deposited on the suit material → Adsorption

#### How do I maintain and care for my chemical protective suit after working with hazardous substances?

You have to assume that the chemical protective suit is contaminated. Therefore, you must decontaminate the suit.

#### MAINTENANCE AND CARE EQUIPMENT FROM DRÄGER

Dräger provides all the equipment for maintenance and care. For maintenance and care the following are required:

- Special industrial washing machines
- Cleaning and disinfecting agents
- Drying systems
- Extensive testing equipment to check for functionality and leaks in accordance with EN 943 or other local requirements – for suits, masks and compressed breathing apparatus

## 5 questions to obtain the right protective suit

- 1. Which hazardous substances are you exposed to during your work?**
  - If you know the hazardous substance, you can take tangible measures to protect yourself. The Dräger VOICE Hazardous Substances Database lets you know which suit protects against which hazardous materials and for how long.
  - If you do not know the hazardous substance, always assume the worst case scenario and select the next higher degree of protection.
- 2. Do you have to wear breathing apparatus during your work?**
  - If no respiratory protection is needed, simple overalls or other protective clothing that protect against the respective chemical agents will be sufficient.
  - If you work with filter equipment, it is best to use a suit equipped with integrated full-face mask or facial sleeve.
  - If you need an SCBA, make sure the equipment is comfortable to wear either over or under your protective suit.
- 3. What is your work environment like**
  - A traffic accident requires you to reach in between or handle sharp-edged objects. A protective suit with a higher mechanical strength, such as a reusable model, is recommended when your work environment is unpredictable.
  - If damage is unlikely, you can also use a limited-use suit\*.
  - When working in confined spaces, such as tanks with manholes, it is best to select a close fitting suit and wear the SCBA over the suit. Thus the SCBA is easier to remove when passing through narrow passages.
- 4. How easily can the pollution caused by the hazardous substance be removed (decontamination)?**
  - If the hazardous substance is difficult to remove from surfaces, you should wear a protective suit with the breathing apparatus worn on the inside of the suit. By this means you can protect it from contamination.
- 5. What are the associated risks of working with the hazardous substance?**
  - If it is a very cold hazardous substance such as liquefied gas, the material of the suit must not become brittle or fracture when exposed to the cold.
  - If the hazardous substance is flammable at ambient temperatures, the protective suit must be flame-resistant.
  - If there is a risk of explosion in the area where the hazardous substance is leaking, the suit must have the relevant electrostatic properties.
  - If the hazardous substance is a toxic gas, only a gas-tight chemical protection suit should be used, never a splash-guard suit.

\*Limited reusable protective suit



D-10084-2010

## What types of respiratory protective devices are there?

Depending on whether the device is closed-circuit or open-circuit, respiratory apparatus is divided into different types.

Respiratory protective devices at a glance:

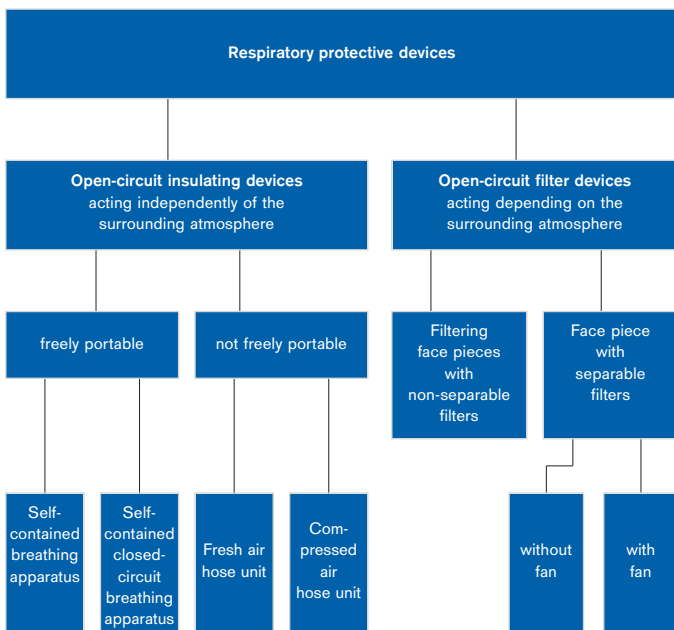

### When should I use respiratory protection?

Wearing respiratory protection is an additional burden. Therefore, you should only consider respiratory protection if the limits in your workplace can be met without any other protective measures.

**Wearing respiratory protection can be avoided with the following protective measures:**

- Substitution of the hazardous substance
- Technical solutions, such as exhausts, ventilation measures or encapsulation
- Organizational measures

### How do I select the right respiratory protection for my field of work?

The guide EN 529 »Respiratory protective devices - Recommendation for selection, use, care and maintenance«; provides important information at the European level. For Germany, the professional association regulation 190 (BGR 190) »Use of respiratory protection«; applies. Within this regulation you can find information about selecting and using respiratory protection and any relevant prerequisites.



SI-3539-2003

## What do I have to consider when wearing respiratory protection for a prolonged period?

Do you want to use the breathing apparatus daily for more than 30 minutes? Then first you have to undergo the preventive medical examination required under convention 26 (BGI 504-26). In addition, you have to comply with fixed recovery times.

Example: Extract from the BGR 190 (November 2009)

Self-contained breathing apparatus (SCBA)	Wearing time (min)	Recovery time (min)	Uses per shift	Shifts per week
over 5 kg total mass	60	30	4	4 (2-1-2) 2 days 1 day rest 2 days
up to 5 kg total mass	contingent on function	10	dependent on wearing time	5

### PLEASE NOTE:

In each country you have to consider other local requirements. The data in the table apply only to Germany.

## How do I use self-contained breathing apparatus?

Self-contained breathing apparatus (SCBA) are freely portable respirators. They are either worn on the back or on the hip with an appropriate harness.

### Specific requirements for SCBA as a safety device according to EN 137: :

- Pressure gauge (manometer) that can easily be read from the wearer's point of view
- Warning device which gives an alarm at a residual pressure of  $55 \pm 5$  bar

EN 137-1: applies to industrial applications

EN 137-2: contains additional requirements for fire fighting

### Example: The Dräger PAS Micro breathing apparatus



### How long can I use a SCBA in one stretch?

The duration of usage for breathing apparatus is between 10 min (short-term SCBA) to about 45 minutes (long-term SCBA). Depending on requirements, you can choose cylinder volume, pressure, and thus the amount of compressed air, specifically for your application. In addition, duration of usage depends on your personal air consumption.

### For example:

Compressed air cylinder:           Volume: 3 l  
                                  Pressure: 200 bar  
                                  Volume of air: about 600 l

average air consumption:           about 40 l/min

Usage time:                   about 15 min

## How do I use a compressed air hose unit?

A compressed air hose unit is a type of not freely portable breathing apparatus. That means: By using a compressed air delivery hose you can supply necessary breathing air from the outside – either from an external air line or via breathing air cylinders provided.

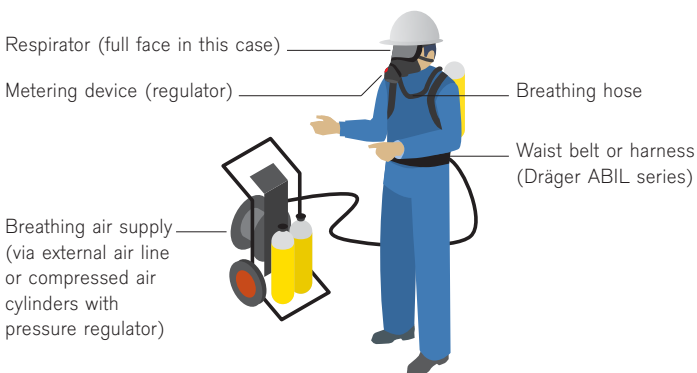

The specifications for compressed air hose units are governed by EN 14593.

There are three different types of compressed air hose units:

- With control valve  
These devices provide a continuous stream of air.  
→ High air consumption  
Use: with stationary air supply
- With normal-pressure regulator  
The breathing air is used only for the inhalation cycle.  
→ Low air consumption  
Application: for air supply from compressed air cylinders
- With pressure regulator  
The units generate an excess pressure of max. 5 mbar in the respirator (e.g. in the full face mask). This is to prevent hazardous substances in the ambient air from entering the mask.  
Application: for example, in atmospheres containing substances that exhibit acute toxicity.



## Which respiratory protection is suitable for which jobs?

Whether you choose a freely portable or a not freely portable breathing device, depends on the conditions of use and intended application. SCBA and compressed air hose units are both open-circuit devices. They both offer the same protection against airborne contaminants and lack of oxygen.

What type of equipment you prefer to rely on at work depends on the conditions of use and intended application.

### Self-contained breathing apparatus

**Advantage:** You can move around freely at work.

**Disadvantage:** Your breathing air supply is limited.

→ Use in tight spaces or for temporary work with respiratory protection

### Compressed air hose unit

**Advantage:** You have an unlimited supply of breathing air.

**Disadvantage:** You are severely limited in your range of motion.

→ Long-term use, such as extended maintenance and cleaning work or if the chemical protective suit needs to be ventilated

## What types of compressed air cylinders are there?

Compressed air cylinders are available with a filling pressure of 200 to 300 bar. The pressure tank is made of steel, aluminum or carbon fiber composites (CFRP). CFRP cylinders are the lightest and therefore offer the highest comfort. The pressure tank is fitted with a shut-off valve. The SCBA's pressure regulator is connected to this valve.

### Design of a carbon fiber cylinder:

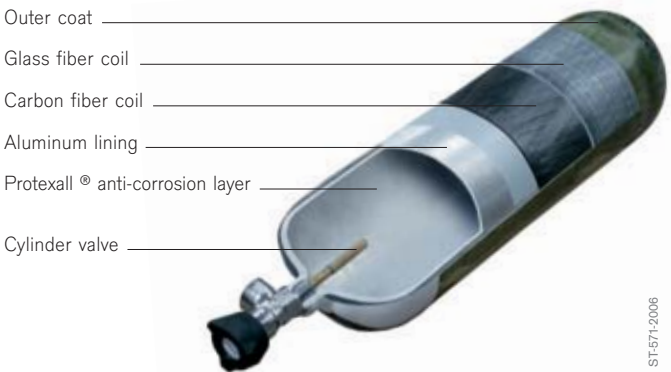

### IMPORTANT NOTES

To prevent the ingress of moisture and contaminants into the cylinder, you should never lower the pressure below 2 bar. Compressed air cylinders must be regularly maintained.

### What information does the compressed air cylinder coding give me?

What are the dangers of the cylinder? What does it contain? The clearly visible cylinder code, in accordance with EN 1089-3, gives you this information. A cylinder with a black and white color on its collar represents a compressed air cylinder. The color coding only applies to the collar of the cylinder.

### A label on the compressed air cylinder provides the following information:

- Composition of the gas mixture
- Risk and safety phrases
- UN number and name of the gas
- Name of the gas manufacturer together with address and telephone number
- Certification date



## How do I use escape equipment?

In your workplace, is there a risk of chemicals suddenly entering the air? Or of there not being enough oxygen in the air? Then you should make sure that you always carry an escape device with you. In an emergency it can save your life, because it provides you with clean air on the way out.

Escape equipment must meet certain requirements. These are governed by EN 529.

What types of self-contained escape devices are there?

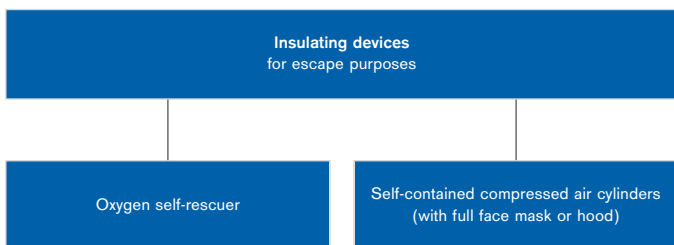

## How do I use a KO<sub>2</sub> self-rescuer?

KO<sub>2</sub> self-rescuers, or chemical oxygen self-rescuers are regeneration escape devices to EN 401. The substance of the chemical cartridge is made of potassium superoxide (KO<sub>2</sub>).

How it works:

- (1) A chlorate starter provides enough oxygen for the first few minutes, before subsequent reaction starts.
- (2) The humidity of the exhaled air (H<sub>2</sub>O) transforms the KO<sub>2</sub> into oxygen (O<sub>2</sub>) and potassium hydroxide (KOH):  $KO_2 + H_2O \rightarrow 2 KOH + 1,5 O_2 + \text{heat}$
- (3) Potassium hydroxide in turn binds the carbon dioxide (CO<sub>2</sub>) in the exhaled air:  $KOH + CO_2 \rightarrow K_2CO_3 + H_2O + \text{heat}$
- (4) Excess oxygen escapes through a pressure relief valve into the ambient air. The resulting heat is dissipated through a radiator.



D-17070-2010

1. Breath from the starter



D-17071-2010

2. First exhalation into the breathing bag



D-17072-2010

3. Inhalation from the breathing bag



D-17073-2010

4. Exhalation with release of excess

### KO<sub>2</sub> SELF-RESCUERS BY DRÄGER

With Dräger you get KO<sub>2</sub> self-rescuers either as a hood variant or as a variant with a mouthpiece, nose clip and goggles.



## What are compressed air emergency escapes?

This escape equipment is a compressed air escape device. Small portable air tanks provide the wearer with fresh air for 10 to 15 minutes – depending on cylinder size. The requirements for compressed air rescuers are described in EN 402/EN 1146.

### How it works

Fresh air is available from the small compressed air cylinder either via a hood or a full face mask with regulator. If the air supply is almost exhausted, a warning whistle sounds on the EN1146 device. Thus the user knows that he must now quickly find a safe environment.

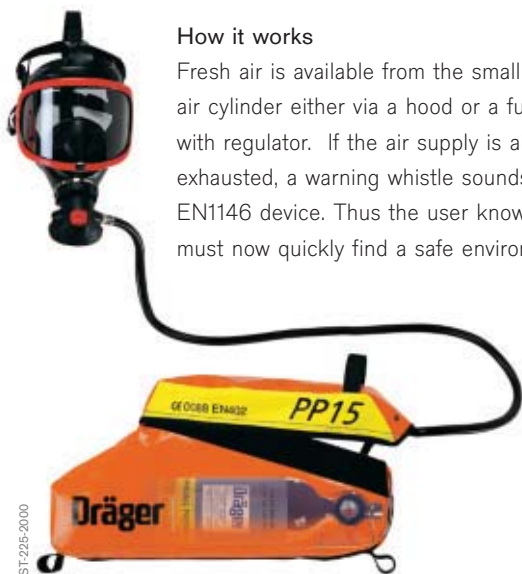

### Which escape device gives what advantages?

#### Compressed air escape device with hood:

- Easy to put on - even by inexperienced users
- Fits regardless of face shape: also suitable for glasses and beards
- Constant flow rate (disadvantage: higher air consumption)

#### Compressed air escape device with excess pressure and full face mask:

- High sealing capacity
- Lower air consumption for users who are accustomed to wearing full face masks
- Allows the wearing protective helmets and ear protection



D-10032-2010

## External air supply

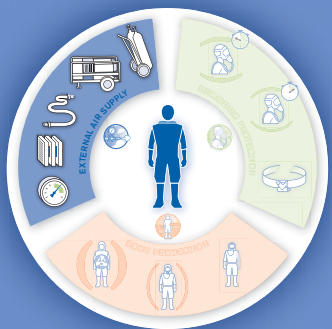

### Air is life

By the age of 68, you will have breathed in about 300,000 m<sup>3</sup> of air – an enormous amount. For this volume, it is vital that the air that flows through your lungs is clean. This applies for ambient air just as much as for air which is supplied to you externally (through a device or a filter). Externally supplied air is necessary if the ambient atmosphere contains contaminants, or not enough oxygen. External air supply includes, for example, air from compressed air cylinders which are filled with breathing air, or air from external breathing air pipes.

## Chemical protective wear

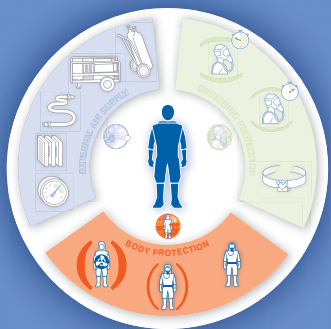

### Head to toe safety

Whether in liquid, solid or gaseous form: chemicals in the air can irritate the skin, damage the body or enter it via the skin – with potentially serious consequences for your health. Therefore, you should protect your skin and that of your employees from hazardous substances in the workplace: for example using goggles, gloves, boots, aprons, or – the complete form of body protection – a chemical protective suit. But what protection is appropriate for which application?

**The correct choice of your protective clothing depends on three factors:**

- The chemicals in your workplace
- Your work
- Ambient conditions

## Respiratory protection

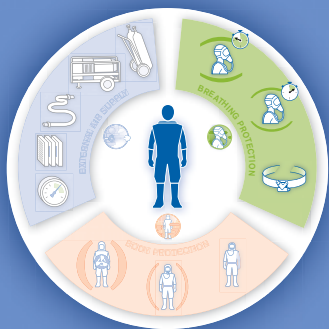

### When breathing is dangerous

Is the concentration of hazardous substances at your workplace too high and/or the oxygen content in the ambient air too low? Then you need respiratory protection. However, wearing respiratory protection always represents an extra burden on your body. So here is the rule of thumb: as much protection as necessary and as little weight as possible.

But how much protection is necessary? The answer to this question depends on your field of application.



## HEADQUARTERS

Dräger Safety AG & Co. KGaA  
Revalstrasse 1  
23560 Lübeck, Germany

[www.draeger.com](http://www.draeger.com)

## SUBSIDIARIES

### AUSTRALIA

Dräger Safety Pacific Pty. Ltd.  
Axcess Corporate Park  
Unit 99, 45 Gilby Road  
Mt. Waverley Vic 3149  
Tel +61 3 92 65 50 00  
Fax +61 3 92 65 50 95

### CANADA

Dräger Safety Canada Ltd.  
7555 Danbro Crescent  
Mississauga, Ontario L5N 6P9  
Tel +1 905 821 8988  
Fax +1 905 821 2565

### P. R. CHINA

Beijing Fortune Draeger Safety  
Equipment Co., Ltd.  
A22 Yu An Rd, B Area,  
Tianzhu Airport Industrial Zone,  
Shunyi District, Beijing 101300  
Tel +86 10 80 49 80 00  
Fax +86 10 80 49 80 05

### FRANCE

Dräger Safety France SAS  
3c route de la Fédération,  
BP 80141  
67025 Strasbourg Cedex 1  
Tel +33 3 88 40 59 29  
Fax +33 3 88 40 76 67

### MEXICO

Dräger Safety S.A. de C.V.  
Av. Peñuelas No. 5  
Bodega No. 37  
Fraccionamiento Industrial  
San Pedrito  
Querétaro, Qro México  
Tel +52 442 246-1113  
Fax +52 442 246-1114

### NETHERLANDS

Dräger Safety Nederland B.V.  
Edisonstraat 53  
2700 AH Zoetermeer  
Tel +31 79 344 46 66  
Fax +31 79 344 47 90

### REP. OF SOUTH AFRICA

Dräger South Africa (Pty) Ltd.  
P.O.Box 68601  
Bryanston 2021  
Tel +27 11 465 99 59  
Fax +27 11 465 69 53

### SINGAPORE

Dräger Safety Asia Pte Ltd  
67 Ayer Rajah Crescent #06-03  
Singapore 139950  
Tel +65 68 72 92 88  
Fax +65 65 12 19 08

### SPAIN

Dräger Safety Hispania S.A.  
Calle Xaudaró 5  
28034 Madrid  
Tel +34 91 728 34 00  
Fax +34 91 729 48 99

### UNITED KINGDOM

Dräger Safety UK Ltd.  
Blyth Riverside Business Park  
Blyth, Northumberland NE24 4RG  
Tel +44 1670 352-891  
Fax +44 1670 356-266

### USA

Dräger Safety, Inc.  
101 Technology Drive  
Pittsburgh, PA 15275  
Tel +1 412 787 8383  
Fax +1 412 787 2207