



Pediatric Anesthesia

Dr. K. Rupp
Dr. J. Holzki
Dr. T. Fischer
Dr. C. Keller

Author:

Dr. Katrin Rupp
Dräger Medizintechnik GmbH
Moislinger Allee 53-55
D-23542 Lübeck

With special thanks to the following people for their kind assistance:

Dr. J. Holzki
Kinderklinik Köln (Children's Hospital, Cologne)
Amsterdamstraße 59
D-50735 Köln

Dr. T. Fischer
Deutsches Herzzentrum Berlin
(German Center for Cardiology, Berlin)
Augustenbürgerplatz 1
D-13353 Berlin

Dr. C. Keller
Klinik für Anästhesie und Allgemeine Intensivmedizin
(Clinic for Anesthesiology and General Intensive Care Medicine)
Leopold-Franzens-Universität Innsbruck
Anichstraße 35
A-6020 Innsbruck

Dräger Medizintechnik GmbH reserves all rights to this publication, especially as pertaining to its duplication and distribution. No part of this publication may be reprinted or saved through any means, mechanical, electrical/electronic or photographic, without the expressed written consent of the Dräger Medizintechnik GmbH.

E-Mail: Katrin.rupp@draeger.com

ISBN 3-926762-48-9

translated by: L.A. Weaver

Pediatric Anesthesia

Important Information:

Medical knowledge is constantly changing as a result of research and clinical testing. The editors and authors of this primer have taken great care to ensure that the information and therapeutic details contained herein correspond to the most up-to-date research results (especially as pertains to indications, dosages and undesirable side effects), they cannot, however, guarantee this. Those persons using this book as a reference are advised to carefully peruse all instructions included with medications used and to make all decisions pertaining to dosage or application at their own discretion.

The Editors

October, 1999

Table of Contents

1. Introduction	8
2. Special Anatomical and Physiological Features	12
2.1 Breathing	13
2.1.1 Anatomical Fundamentals of the Respiratory Tract	13
2.1.2 Controlling the Respiratory Process	15
2.1.3 Respiratory Mechanics	17
2.1.4 Pulmonary Volumes	19
2.1.5 Surfactant	23
2.1.6 Oxygen Requirements	24
2.1.7 Extrapulmonary Oxygen Toxicity	26
2.2 The Heart and Circulatory System	27
2.2.1 The Fetal Circulatory System	27
2.2.2 The Heart	29
2.2.3 Blood Volume and Blood Pressure	30
2.2.4 Hemoglobin Contents	31
2.3 Temperature Regulation	32
2.4 The Balance between Water and Electrolytes	35
3. Anesthetic Agents	37
3.1 Inhalation Anesthesia	38
3.2 Interactions with Soda Lime	45
3.3 Intravenous Anesthesia	49
3.4 Muscle Relaxants	51
4. Anesthesia Accessories	53
4.1 Masks	54
4.2 Tubes	55
4.3 Laryngeal Masks	58

5. Ventilation in Pediatric Anesthesia	60
5.1 Mechanical Modes of Ventilation	61
5.1.1 The Ventilation Mode IPPV	61
5.1.2 The Ventilation Mode SIMV	63
5.1.3 The Ventilation Mode PCV	64
5.2 Ventilation Parameters	73
5.3 Breathing Systems	78
5.3.1 Flow-controlled Non-rebreathing Systems	79
5.3.2 Valve-controlled Non-rebreathing Systems	86
5.3.3 Partial Rebreathing Systems (Semi-closed Breathing Systems)	87
5.3.4 Complete Rebreathing Systems (Closed Systems)	89
5.4 Characteristics of Ventilation for Pediatric Anesthesia	90
5.4.1 Manual and Mechanical Ventilation for Neonates and Infants	90
5.4.2 Respirator Requirements for Children	92
5.4.3 The Fresh-gas Decoupler	94
5.4.4 Compliance Compensation	96
5.4.5 Dead Space Volume	98
5.5 Anesthetic Machines	99
5.5.1 Cato/Cicero EM	99
5.5.2 Julian	101
5.5.3 PhysioFlex	102
5.6 Monitoring	108
5.6.1 The Stethoscope	109
5.6.2 Pulse Oximetry	110
5.6.3 Measuring Body Temperature	113
5.6.4 Measuring Blood Pressure(NiBP/iBP)	115
5.6.5 The ECG	118

5.6.6	Capnography	120
5.6.7	Measuring Respiratory Pressure	125
5.6.8	Volumetry	126
5.6.9	Measuring the Concentration of Anesthetic Agent	127
5.6.10	Measuring the Inspiratory Oxygen Concentration	128
5.6.11	Oxygen Uptake	129
5.6.12	Anesthetic Agent Uptake	130
5.7	Low-flow Anesthesia	132
5.7.1	The Wash-in/Wash-out Rate of Anesthetic Agent	137
5.8	Breathing Gas Conditioning for Anesthetic Ventilation Systems	142
6.	Bibliography	151
7.	Practical Application	161
7.1	Anesthetic Ventilation for Infants and Small Children <i>Dr. J. Holzki</i> <i>Children's Clinic, Cologne, Germany</i>	161
7.2	PCV during Pediatric Cardio-anesthesia <i>Dr. T. Fischer</i> <i>German Heart Center, Berlin</i>	176
7.3	Using a Laryngeal Mask for Pediatric Anesthesia <i>Dr. C. Keller</i> <i>Leopold-Franzens University, Innsbruck</i>	185
8.	Abbreviations	193
9.	Index	196

1. Introduction



*Children
pose many questions
for anesthetists.*

Ventilating Children under Anesthesia

An anesthetic workstation to be used for pediatric anesthesia has to meet numerous requirements and must take into consideration the special physiological aspects of the various age groups of children, from premature babies to school children. Children are not simply to be considered “little adults”. They differ from adults anatomically, physiologically, psychologically, and bio-chemically. These differences are especially marked when comparing premature infants and neonates to adults, and they only begin to recede around a child’s tenth year.

newborns	1 to 28 days
infants	up to end of 1 st year
small children	2 to 5 years
school-aged children	6 to 14 years

Figure 1: Age groups

Many anesthetists who do not care for or administer to infants or small children on a daily basis are somewhat insecure with pediatric patients. A large number of anesthetists were part of a systematic survey which gathered questions on the general topic of pediatric anesthesia and included other specialized topics, for example Dräger products used for pediatric anesthesia. The goal of this primer is, on the one hand, to provide answers for those questions most often asked and, on the other hand, to consolidate, in compact form, the most important basic knowledge in the field of pediatric anesthesia.

It is not the intent of this primer to replace other textbooks, but rather to supplement known textbooks by providing information on practical applications for pediatric anesthesia. Concrete examples for application topics like anesthetic ventilation for small children, pressure-controlled ventilation (PCV), and laryngeal mask usage in pediatric anesthesia, help complete this primer.

The following complex questions on the topics of anesthetic machines, accessories, special physiological features and anesthetics shall be addressed:

- Are the latest anesthetic machines able to ventilate using a pressure-controlled ventilation mode (PCV)? *(p. 64)*
- What are the advantages of pressure-controlled ventilation over volume-controlled ventilation? *(p. 64)*
- Which ventilation parameter settings should be selected for which age group? *(p. 73)*
- Does it make sense to use PEEP, on principle, for each and every case of newborn ventilation? *(p. 75)*
- What usage problems are associated with non-rebreathing systems? *(p. 79)*
- What features does an efficient pediatric respirator have? *(p. 92)*
- How does dead space volume affect ventilation? *(p. 98)*
- How low is the minimum tidal volume which an anesthetic machine can apply? *(p. 99)*
- What are the advantages of closed-system ventilation for pediatric anesthesia? *(p. 104)*
- What kind of monitoring is used for pediatric anesthesia and what special features are available for this age group? *(p. 108)*

- How much is volume-controlled or, respectively, pressure-controlled ventilation affected by a siphoning gas measurement procedure during side-stream capnography? (*p. 123*)
- Can low-flow anesthesia be carried out for pediatric anesthesia? (*p. 132*)
- How quickly does the system react to changes in concentration (wash-in/wash-out rate)? (*p. 137*)
- Why is it necessary to condition breathing gases for children (*p. 143*), and which types of breathing gas humidification should be used for which age group? (*p. 144*)
- Which oxygen concentration is dangerous for neonates? (*p. 26*)
- How high are the anesthetic MAC values for children? (*p. 39*)
- How do inhalation anesthetics interact with soda lime (*p. 46*) and how can this be prevented? (*p. 48*)
- When would one use intravenous anesthesia on children instead of inhalation anesthesia? (*p. 50*)
- When is intubation preferred to mask anesthesia for pediatric anesthesia? (*p. 54*)
- What are the advantages and disadvantages of laryngeal mask usage? (*p. 59*)

These questions shall appear on those pages, indicated by the blue italicized page numbers behind the questions.

2. Special Anatomical and Physiological Features



*The “little” patients
should not be considered
“miniature adults”.*

2.1 1.1 Breathing

2.1.1 Anatomical Fundamentals of the Respiratory Tract

Knowing the differences between the respiratory tract of a child and that of an adult is essential for anesthetists in order for them to safely administer anesthesia.

- A child's nostrils, oropharynx and trachea are relatively narrow (see Figure 2). Breathing can be hindered by irritation of the mucous membrane due to edema build-up in this area.
- The trachea is short – it only measures approximately 4 cm from the larynx to the carina – and has a narrow diameter of 6 mm.
- The tongue is relatively large and tends to fall backwards under anesthesia.
- Neonates, infants and small children have a very soft thorax compared to their lungs. The thorax is relatively short. The ribs run horizontally and not diagonally, as is the case with adults. The intercostal muscles are immature.
- The salivary secretions of children are more pronounced than those of adults.
- The larynx of a child is more ventrally located and on level with the third to fourth (neck) vertebrae, thus about a whole vertebrae higher than that of an adult. Until the age of 8 to 10 years, the most narrow point is a very sensitive mucous membrane on level with the larynx cartilage and not, as is the case with adults, with the glottis.
- The epiglottis is relatively large and shaped like a U.
- The size of the tonsils and the adenoid in children can complicate the intubation process.

- Infants breathe through their nose until they reach an age of 5 months. Inserting a stomach probe through the nose can be a massive respiratory hindrance.

Figure 2: Sagittal tomogram of a newborn and an adult

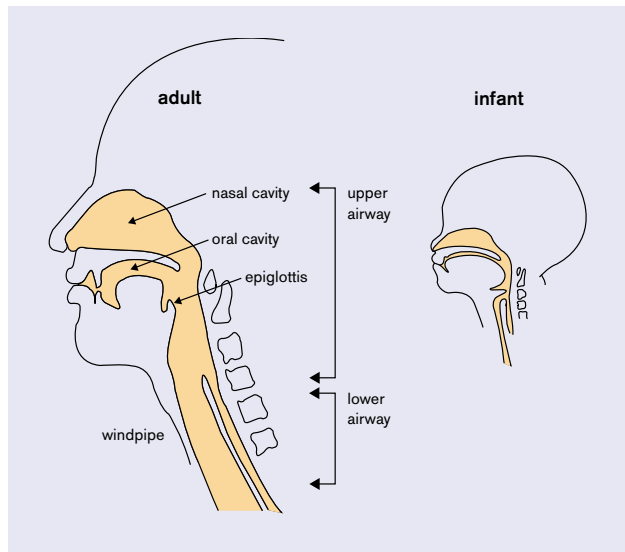

2.1.2 Controlling the Respiratory Process

The respiratory process of both premature newborns and neonates, like that of adults, is essentially controlled by changes in $p_a\text{CO}_2$, $p_a\text{O}_2$ and pH (see Figure 3). The hypoxia breathing regulation of newborns is not, however, fully developed; right after birth, the oxygen receptors and their functions are immature. The $p_a\text{CO}_2$ and $p_a\text{O}_2$ values of newborns and infants are lower than those of adults until the end of their first year.

Premature infants often experience respiratory arrest (apnea) either at regular (periodical breathing) or irregular intervals. Periodical breathing is considered an episode of 3 or more respiratory pauses of at least 3 seconds. Normal breathing periods of less than 20 seconds accompany these. Apnea phases can be due to a central problem (no physical breathing exertion) or, less often, caused by an obstruction (no flow despite physical breathing exertion). In addition, there are mixed forms of both. Nevertheless, these breathing abnormalities are not usually dangerous. Respiratory arrest can, however, lead to decreased O_2 partial pressure in the blood and can cause bradycardia if the length of such a phase is longer than 30 seconds.

Infants react to hypoxia biphasically. First there is a 30 second increase in minute volume, followed by hypoventilation or apnea. If hypothermia or hypoglycemia occurs simultaneously, hypoventilation is the immediate result. An adequate reaction to lack of oxygen on the part of the child can only be observed 2 to 4 weeks after birth.

The breathing regulation of premature newborns and neonates continues to be influenced by pulmonary compliance. Compliance triggers breathing reflexes via the mechanoreceptors. The most well-known reflex is the inspiratory repressive Hering-Breuer reflex which is especially noticeable in premature babies (born between the thirty-second and thirty-eight week of pregnancy) with little pulmonary compliance. This effect decreases as the neonate matures. Ventilating with high tidal volume, which may cause the lungs to overinflate, leads to an inhibition of reflexes in the central breathing system's inspiratory neurons and, thus, to an interruption and extension of the expiratory phase.

It is thought that this reflex protects the system from respiratory fatigue caused by ineffective muscle work and from volutrauma [Davis, 1987; Mortola, 1998].

Figure 3: Children's respiratory regulation

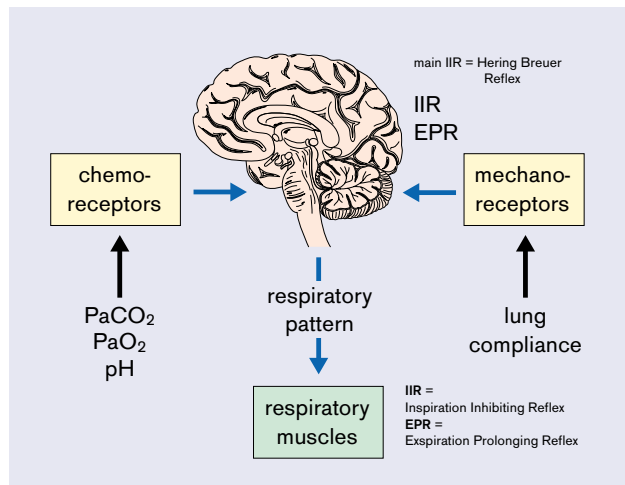

2.1.3 Respiratory Mechanics

A newborn's pulmonary compliance (or elasticity) is very low and does not differ greatly from the total compliance (i.e. compliance of the lungs and thorax). A newborn's thorax is substantially more elastic than an adult's and offers little resistance to e.g. overinflation. As a child grows older, the total compliance increases (see Table 1).

	newborns	infants	small children	school-aged children
age	1 to 28 days	up to 1 year	2 to 5 years	6 to 14 years
weight	2.5 to 5 kg	5 to 10 kg	10 to 20 kg	> 20 kg
compliance (ml/mbar)	5	10 to 20	20 to 40	100

Table 1: The relationship between age and compliance

In newborns and infants, the diaphragm does almost all the work expended for breathing. Abdomen hindrances, for example due to intra-abdominal pressure, can lead to insufficient spontaneous breathing.

Pulmonary compliance can be reduced due to many causes, for example:

parenchyma changes

- bronchopneumonia
- pulmonary edema
- ARDS
- fibrosis

functional surfactant disorders

- alveolar pulmonary edema
- atelectasis
- aspiration
- RDS/ARDS

reduced volume

- pneumothorax
- raised diaphragm

[Oczenski, 1997]

2.1.4 Pulmonary Volumes

Relative to its size, the volume of a child's lung is equivalent to that of an adult's. An infant born after a full-term pregnancy has a total lung capacity of approximately 160 ml, a functional residual capacity of 80 ml and a tidal volume of approximately 16 ml. One-third of the tidal volume is equal to the dead space volume. The proportion, dead space volume to tidal volume, remains constant for spontaneously breathing children, it can, however, increase during controlled ventilation. In order to keep total dead space volume to a minimum, accessories of the anesthetic systems should be operated using the smallest possible dead space available, especially when ventilating an infant with a dead space volume of only 5 ml (see Chapter 5.4.5, Dead Space Volume).

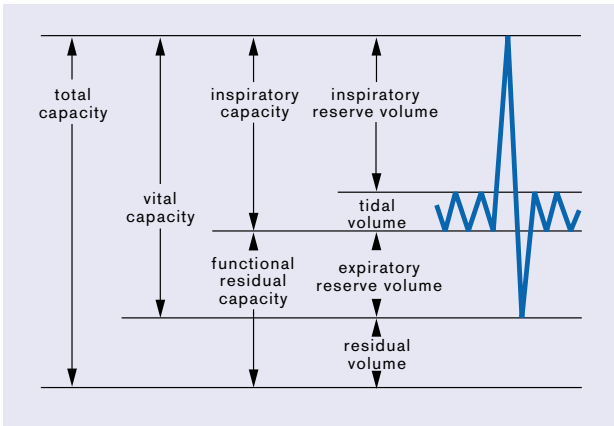

Figure 4: Static tidal volumes [Lotz, 1984]

The following static tidal volumes can be distinguished:

- total capacity (TC): includes total air volume in the lungs after a maximal inspiratory phase ($TC = FRC + IC$)
- vital capacity (VC): the maximum volume which can be exhaled after a maximal inspiratory phase ($VC = ERV + IC$)
- residual volume (RV): the volume remaining in the lungs after a maximal expiratory phase
- functional residual capacity (FRC): the volume remaining in the lungs after a normal expiratory phase ($FRC = RV + ERV$)
- expiratory reserve volume (ERV): additional volume which can be exhaled after a normal expiratory phase
- tidal volume (V_T): the volume normally inspired and expired
- inspiratory capacity (IC): the maximum volume which can be inspired ($IC = V_T + IRV$)
- inspiratory reserve volume (IRV): additional volume which can be inspired after a normal inspiratory phase

In addition to the above tidal volumes, *closing volume* is important (see Table 2). Although all respiratory paths are open in a completely filled lung, decreasing expiratory volume may cause peripheral paths to become blocked. The closing volume of infants and small children is rather large compared to that of adults. It could exceed the functional residual capacity and, during normal ventilation, impair tidal volume.

Intubation eliminates physiologically intrinsic PEEP in the larynx area, which counteracts peripheral respiratory path blockage. Autogenic PEEP can be compensated for in most anesthetic machines by using a slightly extrinsic PEEP of about 3 mbar, or by implementing the system ALICE [automatic lung inflation control effect] (see page 104).

The *alveolar ventilation* (ventilation of the alveoli for the purpose of pulmonary/blood gas exchanges) of a child, 100 to 150 ml/kg/min, is twice as high as that of an adult. This is achieved mainly through an increased respiratory rate, not through increased tidal volume (V_T). The ratio of alveolar ventilation to functional residual capacity is 5:1 for infants and 1.5:1 for adults. As a result, the functional residual capacity of an infant is only a slight “buffer” against fluctuations of breathing gas and anesthetic agent concentrations so that changes in anesthetic agent concentrations are reflected very quickly in the arterial blood gas values.

Any reduction in functional residual capacity, e.g. by anesthetics, can lead to blockage in the smaller paths of the respiratory tract, uneven breathing gas distribution, and hypoxemia.

Table 2: Average respiratory rates, tidal volumes and resistance values according to age

	newborns	infants	small children	school-aged children
age	1 to 28 days	up to 1 year	2 to 5 years	6 to 14 years
weight	2.5 to 5 kg	5 to 10 kg	10 to 20 kg	> 20 kg
respiratory rate (min ⁻¹)	40 to 60	30 to 60	30 to 40	12 to 20
tidal volume (ml kg ⁻¹)	8 to 10	8 to 10	8 to 10	8 to 10
resistance (mbar L ⁻¹ s)	40	20 to 30	20	1 to 2

Respiratory resistance in newborns is high. This is due to the smallness of the inside diameter of the nostrils, the minute diameter of the smaller bronchi and low tidal volume. During an operation, significant fluctuations in respiratory resistance can occur. For example, bronchial dilatatorical effects from volatile anesthetics reduce respiratory resistance while even the slightest swelling or accumulation of fluids in the respiratory tract, or the tiniest obstruction in the tube area can increase total flow resistance.

2.1.5 Surfactant

Surfactant is a surface-active substance found on the alveolar surface which is synthesized by type 2 alveolar cells and released during inspiration. Surfactant mainly consists of lipoproteins made of lecithin. It stabilizes the alveoli and prevents them from collapsing during the expiratory phase. In addition to this, surfactant reduces the risk of too little ventilation and atelectasis build-up. Premature newborns suffer from respiratory distress syndrome (RDS) because their surfactant is not yet mature; surfactant first matures in the thirty-fifth and thirty-sixth weeks of pregnancy. Although hypo- and hyperoxia, acidosis and hyperthermia can affect surfactant development, the anesthetic agents of inhalation anesthesia seem to have little influence on surfactant production. Those newborns with insufficient surfactant will have a considerable amount of trouble with pulmonary gas exchange. These children usually require ventilation.

When premature newborns are treated with surfactant, functional residual capacity (FRC) builds up during the first 6 to 12 hours after application. The dynamic compliance of the lungs can only increase after this time lapse has occurred. It is important to monitor tidal volume and reduce pressure simultaneous to applying surfactant in order to prevent potential pneumothorax build-up. Any surfactant already generated can be destroyed again by delivering 100 % oxygen, by aspiration pneumonia or by ventilating too aggressively, e.g. by applying a tidal volume which is too high.

2.1.6 Oxygen Requirements

At 7 ml/kg x min, the oxygen needs of a neonate or a premature newborn are about twice as high as that of an adult (see Table 3). At the same time, the level of oxygen consumption depends on the child's state of health, bodily maturity, and stress due to cold. For example, post-operative hypothermia causes an increase of 15 to 16 ml/kg x min, whereas the oxygen required under anesthesia decreases as the body temperature sinks.

Table 3: Interdependency of oxygen consumption and functional residual capacity to body weight

	oxygen consumption	functional residual capacity
5 kg	9 ml/kg x min	10 ml/kg
10 kg	7 ml/kg x min	15 ml/kg
20 kg	6 ml/kg x min	30 ml/kg
adults	3.5 ml/kg x min	

Newborns and infants are significantly more susceptible to hypoxia than adults because of higher oxygen consumption levels, higher alveolar ventilation (twice that of adults), and little functional residual capacity; the latter is reduced even more after anesthetics have been administered (60 % vs. 30 %). The small oxygen reserve available to a newborn or small child is quickly used up; hypoxia can occur within 10 to 20 seconds after an apnea. For comparison, an adult has a length of tolerance of 2 to 3 minutes (see Figure 5) [Frei, 1994].

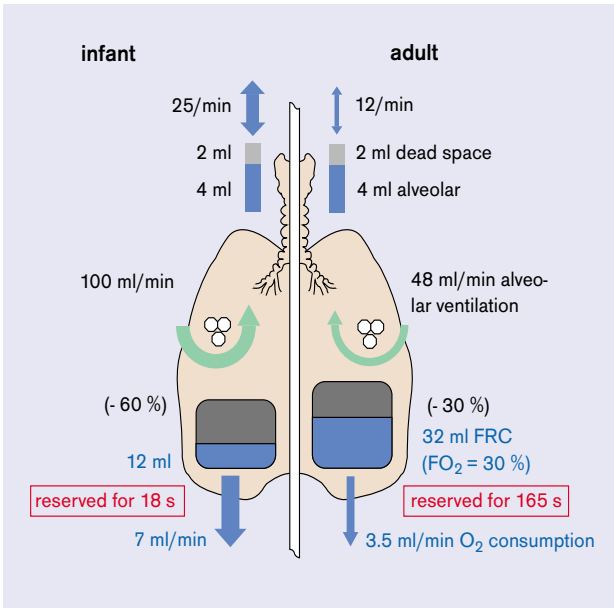

Figure 5: Comparing infants and adults (standardized weight in kg); an infant can go into a hypoxic state within 10 to 20 seconds after an apnea because it has less oxygen reserve than and twice as much oxygen consumption as an adult

Premature newborns < 1500 g do not react to a lack of oxygen, like an adult, with a tachycardia, but rather with a reduced heart rate (bradycardia). This state is not remedied by administering medication, like Atropine, but by sufficiently ventilating the patient and increasing the oxygen supply [Jöhr, 1998].

Which oxygen concentration is dangerous for premature infants?

2.1.7 Extrapulmonary Oxygen Toxicity

Their immature state and contact with partial oxygen pressures which are too high put premature infants at risk of going blind (retinopathy of prematurity). This risk increases with the degree of immaturity, the duration of oxygen application and the height of the partial pressures.

Premature infants born before the forty-fourth week of pregnancy and exposed to a p_aO_2 of more than 80 mmHg for more than 3 hours, or a p_aO_2 of more than 150 mmHg for more than 2 hours, are in acute danger [Shann, 1988]. For this age group, an oxygen saturation level of 90 to 95 % should be targeted using pulse oximetry in order to avoid p_aO_2 values of > 70 mmHg (see the oxygen dissociation curve for premature infants on page 111).

The risk of damaging the retina by excessive partial pressure depends on age and is almost non-existent when premature infants reach the infant stage.

2.2 The Heart and Circulatory System

2.2.1 The Fetal Circulatory System

The lungs of a fetus are not ventilated before birth and are only supplied with very little blood. Oxygen-enriched blood is carried from the placenta of the mother through the vena cava inferior to the right atrium. The main portion of this blood flows through the foramen ovale directly into the left atrium without being mixed with other blood. It is transported to the brain through the aorta ascendens and the carotid artery while blood pushed from the right ventricle is pumped into the aorta through the ductus arteriosus. All this causes high pulmonary tissue resistance to be present, with a right-to-left shunt via the ductus arteriosus and the foramen ovale (see Figure 6).

Lung tissue resistance decreases shortly after birth as a result of lung expansion and an increased p_aO_2 value in the alveoli. The result is functional blockage of the ductus and the foramen ovale. After only 6 to 18 weeks, this blockage becomes permanent. Before this, however, the ductus of a newborn can be reopened by acidosis and/or hypoxia.

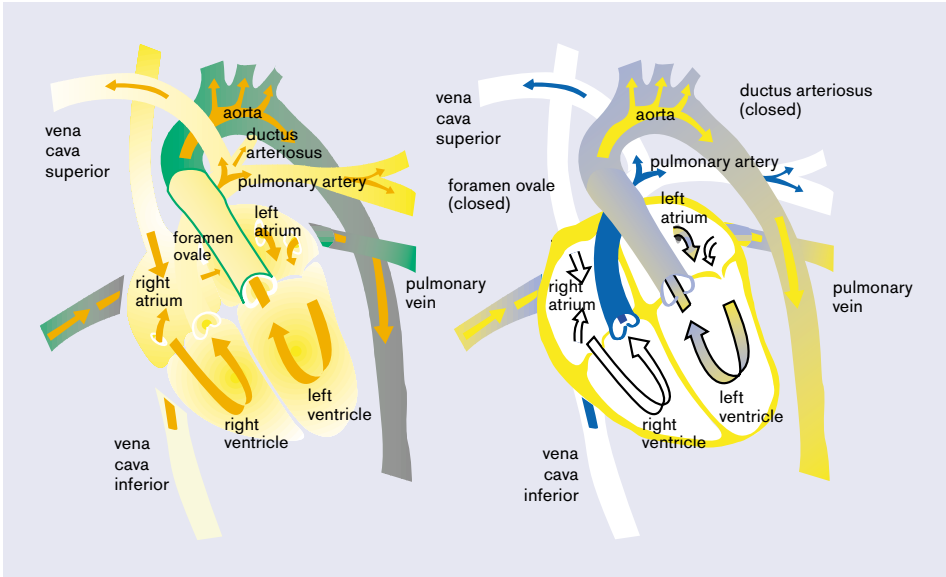

Figure 6: Circulatory system of a fetus and a newborn

2.2.2 The Heart

The heart of a newborn has fewer contractile elements than that of an adult. Because the metabolic rate is raised, cardiac output is relatively high: infants 200 ml/kg/min; adults 70 ml/kg/min. Cardiac output can only be increased by increasing the heart rate. Systolic discharge cannot be increased significantly.

The normal resting heart rate of a newborn is approximately 120 beats per minute, but the breadth for variation is wide (see Table 4). Heart rhythm disorders are often observed in infants. Extra ventricular systoles occur quite often during anesthesia induction, especially when the depth of anesthesia is insufficient. These disorders can, however, be removed by deepening anesthesia. However, in this case there must be no risk of hypoxemia and hypercapnia.

age	heart rate		
	average	lower limit	upper limit
newborns	120	90	170
1 to 12 months	120	80	160
2 years	110	80	130
4 years	100	80	120
6 years	100	75	115
8 years	90	70	110
10 years	90	70	110

Table 4: Heart rates according to age [Kretz, 1998]

2.2.3 Blood Volume and Blood Pressure

A child's blood pressure is lower than an adult's blood pressure, and it increases in proportion to age (see Table 5). The rule of thumb for premature infants is: mean arterial pressure (MAP): 1 mmHg per week of pregnancy. Blood pressure sinks under anesthesia; it should not drop below 50 mmHg for infants and 30 mmHg for premature newborns.

Table 5: Average systolic and diastolic blood pressure values according to age [Versmold, 1981]

age	systolic (mmHg)	diastolic (mmHg)
newborns	75 to 85	40 to 50
2 weeks to 4 years	85	60
6 years	90	60
8 years	95	62
10 years	100	65
15 years	115	72

The blood volume of children is, when compared to their weight, larger than that of adults and decreases with age (see Table 6). The total amount of blood is, however, low; the slightest loss of blood can lead to lack of volume and anemia.

Table 6: Average blood volume values according to age [Jöhr, 1998]

	premature newborns	neonates	small children	adults
blood volume (ml/kg)	95	85	80	70

2.2.4 Hemoglobin Contents

The hemoglobin of an infant consists of fetal (HbF) and adult (HbA) hemoglobin and often varies during the first 6 months (see Figure 7). Compared to HbA, HbF has higher oxygen affinity, making it more difficult for the oxygen to be transferred to body tissues. Increased hemoglobin at birth, about 200 g/l blood, compensates for this deficiency. This value decreases greatly, as low as 100 g/l blood depending on the individual, within the first 3 months as fetal hemoglobin is replaced with adult hemoglobin. After this phase, it increases again (see Table 7). In the case of premature newborns, the hemoglobin value decreases more rapidly and reaches lower points.

age	hemoglobin (g/l)
1 to 7 Tage	160 to 200
1 to 4 weeks	110 to 160
2 to 3 months	100 to 120
1 year	100 to 120
5 years	110 to 130

Table 7: Hemoglobin values according to age

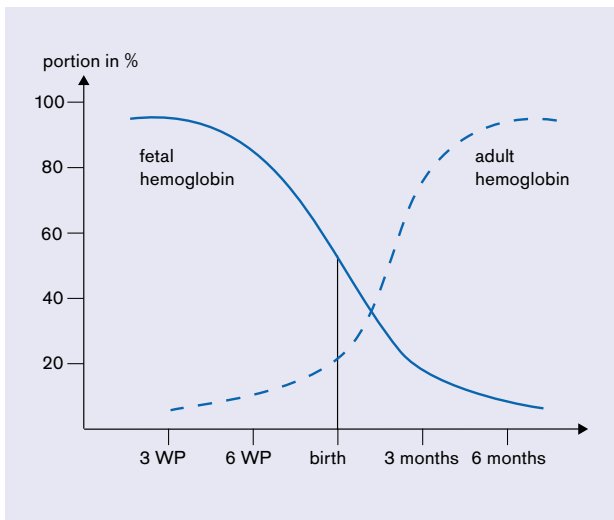

Figure 7: Portions of fetal and adult hemoglobin in the blood (WP: week of pregnancy)

2.3 Temperature Regulation

One of the anesthetist's main tasks during anesthesia is maintaining the patient's body temperature. Infants and small children are especially susceptible to hypothermia both during and after an operation. Children absorb and give off heat more quickly than adults because they have a relatively large body surface compared to their size and because their skin is thin and has little subcutaneous fat.

Infants and small children are not able to produce heat by shivering. Postoperative shivering appears only at about six years. Until then, heat is produced by increasing metabolism, for which so-called "brown adipose tissue" is broken down.

During an operation, thermal regulatory responses to hypothermia only begin if the body temperature deviates greatly from the usual ($< 35.5^{\circ}\text{C}$), and heat is transferred from the core of the body to the periphery. Figure 8 compares the slightness of a neonate's core temperature constant to that of an adult's when ambient air temperature changes.

Anesthetic agents like halothane or isoflurane (see Chapter 3) lead to an even greater loss of heat due to periphery vasodilation. If hypothermia occurs during anesthesia, the recovery time of the child could be delayed. Respiration, heart rate, blood pressure, and/or cardiac output could decrease, and the effectiveness of non-depolarized muscle relaxants could increase. The need for oxygen decreases if the body temperature sinks sharply, and the metabolic rate decreases by 6 to 7 % per degree Celsius.

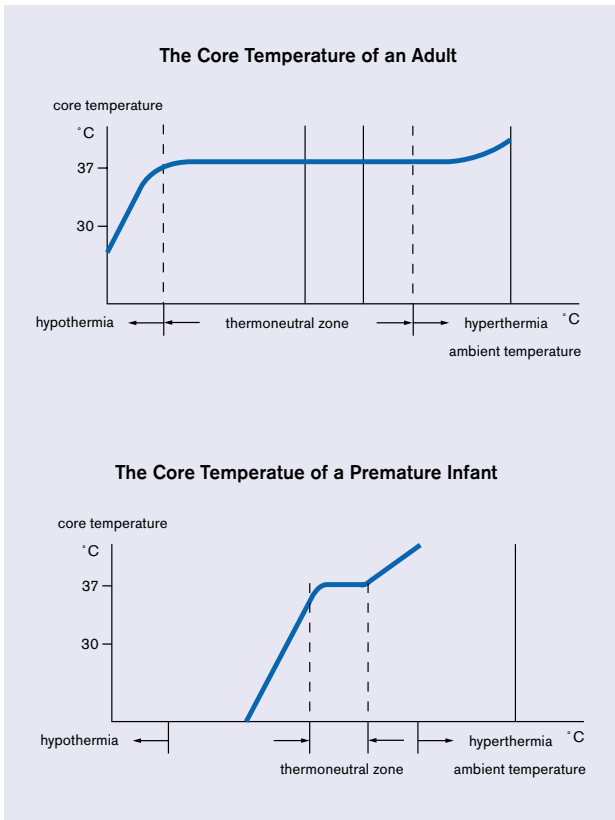

Figure 8: Changes in core temperature for premature infants and adults

Hypothermia can also lead to hypoxia, acidosis, and hypoglycemia.

These are the reasons why measures must be taken to preserve the body heat and protect the patient from hypothermia. Such measures are many-sided (see Table 8) and depend upon the length of the operation to be undertaken, as well as the age of the child.

Table 8: Measures to be taken for maintaining constant body temperature

- Transport newborns in an incubator.
- Use a heating pad.
- Warm the operating theater to between 26 and 30 °C.
- Limit the length of time that the child is uncovered.
- Use a warmer during the pre-op phase.
- Use a baby bonnet.
- Cover the child's extremities (e.g. with cotton).
- Monitor body temperature closely.
- Pre-warm and humidify breathing gas (see page 142).

2.4 The Balance between Water and Electrolytes

Small children have a large amount of water in their bodies. The water content of a premature infant can account for up to 90 % of its weight. Of this, extracellular volume accounts for up to 60 %. The body weight of children aged one-and-a-half or older has a water content closer to that of an adult, i.e. 60 %. Of this, extracellular volume accounts for only 20 %. Intracellular water increases parallel to increasing muscle mass as the child grows older (see Figure 9).

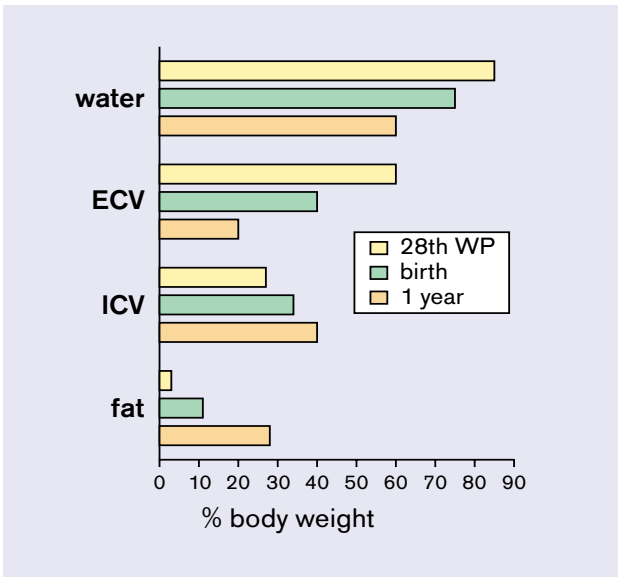

Figure 9: Body composition according to age (ECV: extracellular volume, ICV: intracellular volume)

Small children, who consequently require larger quantities of liquid, tend to dehydrate quicker than adults if a loss of liquid is not compensated for. Other reasons why infants and newborns need relatively large amounts of liquids are a higher basic metabolic rate and the kidneys' inability to concentrate urine (see Table 9). The excretion functionality of infants' kidneys, which includes regulating the balance of sodium, is greatly restricted until the age of one-and-a-half.

Table 9: Basic water requirements

	weight	liquid requirements
adults	70 kg	1.5 ml/kg/h
school-aged children	50 kg 20 kg	2.0 ml/kg/h 3.5 ml/kg/h
small children	13 kg	4.0 mg/kg/h
infants	10 kg	5.0 ml/kg/h

3. Anesthetic Agents



*A suitable choice of anesthetic agents
is adapted especially for little patients.*

3.1 Inhalation Anesthesia

Many anesthesiologists consider inhalation anesthesia the ideal method of application for children. When administering anesthetic agents and other medication, anesthesiologists need to bear in mind that dosages cannot be transferred from adults to newborns and small children one-to-one. Reasons for this include the varying nature of the absorption and distribution of anesthetic agent in a child, as well as the child's metabolism.

Newborns and small children absorb anesthetics faster than adults due to a high alveolar ventilation rate and a smaller blood-gas distribution coefficient for anesthetic agent (less blood solubility). For example, a newborn's blood-gas distribution coefficient for halothane, enflurane and isoflurane is 18 % lower than a young adult's (20 to 40 years old), and for small children it is still a good 12 % lower.

The distribution of anesthetic agent is influenced by a large amount of extracellular space and a difference in membrane permeability (immature blood/brain barriers). The metabolic rate for anesthetic agent (passing through the liver) is often slower because the metabolic paths of newborns are immature.

Amounts of Anesthetic Agent

How high are the anesthetic MAC values for children? MAC (minimal alveolar concentration) values, meaning that 50 % of all patients react to a surgical stimulus, depend on age [Quasha, 1991] (see Table 10). Although small children require higher concentrations of anesthetic agent than adults, newborns need less to reach the same depth of anesthesia (see Figure 10). Reasons for this are widely discussed and include: immaturity of the brain, residual level of progesterone from the mother, and a high level of endorphins.

How high are the anesthetic MAC values for children?

	halothane	isoflurane	sevoflurane	enflurane	desflurane
MAC (%)					
newborns	0.87	1.6	3.3	–	9.2
1 to 6 month	1.2	1.87	3.1	–	9.4
0.5 to 1 year	0.97	1.8	2.7	–	9.9
1 to 12 years	0.89	1.6	2.55	1.7	8.0 to 8.7
adults	0.77	1.15	1.71	1.6	6.0

Table 10: MAC values for anesthetic agent according to age [Gregory, 1994; Inomata, 1994]

When nitrous oxide is added (70 %) to agent intended for children, the MAC values decrease: sevoflurane by 20 to 25 %, halothane by 60 %, isoflurane by 40 % and desflurane by 25 %. The MAC values of sevoflurane and desflurane for adults decrease by half.

Figure 10: MAC values according to age [Le De, 1987] (NB: newborn, WP: week of pregnancy)

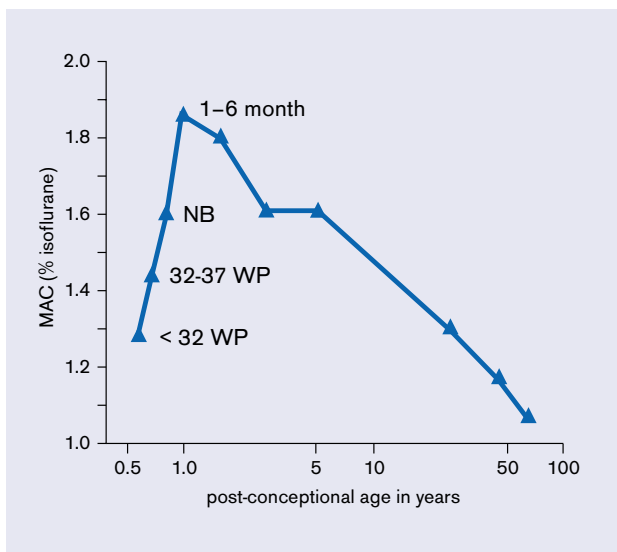

Nitrous Oxide

Nitrous oxide, a rather odorless gas with good analgesic properties, is used as a supplement in general anesthesia. It is not a potent anesthetic (MAC 105 %) and has, by reason of its low solubility in the blood, a very rapid wash-in/wash-out rate. Nitrous oxide, which has little effect on the functionality of the circulatory system, should not be used on newborns and children with pulmonary infections since, in this case, it could trigger so-called diffusion hypoxia. In addition, it could be contraindicate of heightened intracranial pressure or marked ileus [Loop].

Halothane

Next to nitrous oxide, halothane remains the most widely used anesthetic agent in pediatric anesthesia. Reasons given for halothane's suitability for children include the ability to introduce the mask agreeably due to a pleasant, non-pungent smell, potency and price. Halothane does, however, have a grave side-effect: the myocardium's increased sensitiveness to circulating catecholamines. This can lead to increased occurrences of intra-operative arrhythmia. In addition, halothane can cause liver damage in adult patients. Indications of liver damage to pediatric patients repeatedly under anesthesia are, however, considerably lower and furthermore, are considered to be a justifiable risk in most cases [Conzen, 1998]. Other properties of this agent are described in Table 11 and compared to the other four anesthetic agents.

Isoflurane

The use of isoflurane in pediatric patients is controversial. Isoflurane, which irritates the respiratory tract, often leads to laryngospasms in children who have not received pre-medication prior to the induction phase. This gas is, thus, used less often for initiating anesthesia in pediatric patients and more often for maintaining a specific depth of anesthesia. Due to its low metabolic rate of 0.2 %, isoflurane is the preferred anesthetic agent for children with marked liver damage.

Sevoflurane

In 1995, anesthetists began using another inhalation anesthetic, sevoflurane, for pediatric anesthesia. This anesthetic gas, as pleasant smelling as halothane, does not irritate the respiratory tract and has little effect on the cardio-circulatory system. A lower blood-gas distribution coefficient means that anesthetic induction and the recovery phase are shorter with sevoflurane than with halothane, and pediatric patients have less postoperative nausea and vomiting. The shortened recovery time coupled with a more rapid recovery of perception, may produce a state of restlessness [Holzki, 1999].

Enflurane

Enflurane is not widely used in pediatric anesthesia due to possible epileptic effects, a great depression of breathing, higher fluoride concentrations and an ether-like smell. This gas is more potent than sevoflurane but less so than halothane.

Desflurane

Desflurane, less potent than other gases (MAC 8-9 %), has (like sevoflurane) a low blood-gas distribution coefficient and, thus, allows for quicker and more exact adaptation to the depth of anesthesia. Quick gas induction and speedy removal from the blood are the reasons for this. Compared to sevoflurane, however, desflurane is not very suitable for mask induction in pediatric anesthesia because of its ether-like smell. This is why desflurane is the preferred agent used for maintaining general anesthesia during pediatric anesthesia rather than for an inhalation induction. It is also especially suitable for prolonged anesthesia because it has the lowest fatty tissue/blood distribution coefficient of all five gases. Side-effects include respiratory tract irritation, apnea and laryngospasms [Mielke, 1998].

Xenon

When considering the odorless, colorless inert gas xenon, the question arises as to whether this gas could be the ideal anesthetic agent of the future. The properties of this inert gas are considered excellent. Low solubility (blood-gas distribution coefficient: 0.14) means that the induction/removal phase is very short. When a mixture of 30 Vol. % oxygen and 70 Vol. % xenon is used, the analgesic effect is excellent. In addition, xenon has no effect on the hemodynamics or compliance of the lungs. Xenon is also considered environmentally friendly. Since this gas is only available in limited quantities, its use is extremely costly. Means must be found to scavenge the gas by using special scavenging equipment or it must be sparingly used (for example by implementing a closed rebreathing system). Xenon is not yet registered nor is it validated for pediatric anesthesia.

	halothane	isoflurane	sevoflurane	enflurane	desflurane
blood-gas distribution coefficient:					
• newborns	2.1	1.2	0.7	1.8	–
• children (3 to 7 years)	2.4	1.3	–	–	–
• adults	2.7	1.5	0.6	1.9	0.4
irritation during mask ventilation	seldom	occasionally	seldom	occasionally	often
respiratory depression	yes	yes	yes	yes	yes
myocardia depression	yes	yes	yes	yes	yes
cardiac output	decreases sharply	remains the same	drops	drops	drops
tachycardia	no	yes	no	no	no
ventricular arrhythmia	yes	seldom	seldom	seldom	seldom
blood circulation	increases < 1 MAC	slightly increased < 1 MAC	slightly increased	increases < 1 MAC	–
metabolic rate	20 %	< 1 %	3.3 %	2.4 %	0.02 %
fluoride release	no	irrelevant	yes	yes	no

Table 11: Properties of anesthetic agents [Frei, 1998]

3.2 Interactions with Soda Lime

The fact that patient gas is rebreathed in partial and closed re-breathing systems makes it imperative that CO₂ be safely eliminated. To achieve this, an absorber filled with soda lime is built into the breathing circuit. Soda lime used, for example, in Germany Dräger sorb 800 Plus, is composed of 75 to 85 % calcium hydroxide, 1 to 4 % nitrous hydroxide and 14 to 18 % water (soda lime). Barium lime, used almost exclusively in the USA, is made up of 65 % calcium hydroxide, 1 to 4 % potassium hydroxide, and about 35 % barium hydroxide which binds approximately 15 % constitutional water. Both kinds have a colored indicator which allows the anesthetist to see when the absorber should be replaced.

The neutralization reaction begins with carbonic acid being formed from expiratory carbon dioxide and water. After that, nitrous carbonate is created from nitrous hydroxide, which then combines with calcium hydroxide to make a calcium carbonate. This process releases nitrous hydroxide, allowing new reactions with carbon dioxide to take place [Förster, 1999].

Since carbon dioxide can only be absorbed if soda lime is available in a hydrated form, Dräger sorb 800 or 800 Plus, for example, is provided with a moisture level of 14 to 18 %. Carbon dioxide cannot be eliminated if the level of moisture falls below 4 %.

How do inhalation anesthetics interact with soda lime?

If the soda lime dries out, regardless of the type of soda lime or the type of inhalation anesthetic used, undesired reactions are generally the result, but which kind depends on the degree of dryness. Typical reactions include reduced CO₂ absorption, the formation of carbon monoxide, absorption and decomposition of anesthetic agent, increased heat in the absorber and, thus, higher breathing gas temperatures.

These reactions could endanger the pediatric patient with carbon monoxide poisoning, a depth of anesthesia which is too shallow, and/or respiratory tract burns.

Using moist soda lime can, however, also lead to by-products of decomposition. The most well-known product of the decomposition of sevoflurane is so-called Compound A (see Figure 10). This compound is a nephrotoxic vinyl ether. The amount of concentration generated depends on the type of soda lime used, the temperature of and level of moisture in the soda lime, the amount of fresh-gas flow, and the composition and concentration of the gas.

Several factors favorable to Compound A generation include:

- higher interaction with barium lime than with soda lime
- increased bonding during low-flow and minimal flow anesthesia
- high temperatures (= increased production of CO₂)
- reduced level of moisture in CO₂ absorber

Compound A is described as nephrotoxic in laboratory rats. There have, however, been no reports of human kidney damage caused by Compound A. The reason for differences in nephrotoxicity between humans and rats seems to lie in an increase of enzymatic activity of the β -lyase during the metabolic processing of Compound A [Bito, 1998].

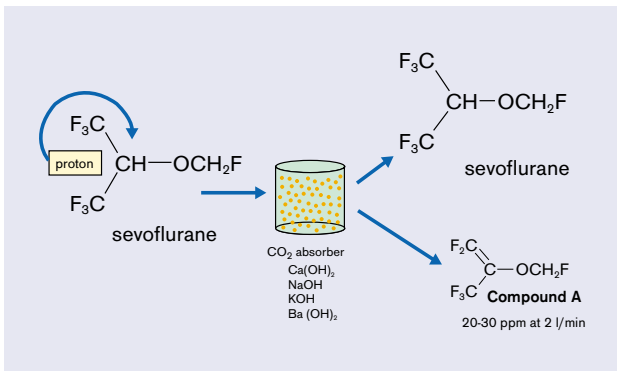

Figure 11: The by-product "Compound A" of the decomposition of sevoflurane

Children, however, have smaller concentrations of by-products from anesthetic agents compared to adults because children on the whole expire less carbon dioxide than adults.

How can interactions between soda lime and inhalation anesthetics be prevented?

Tips for Soda Lime Usage

The Dräger Medizintechnik GmbH and the DGAI [German Association of Anesthesiology and Intensive Care] recommend the following measures be taken to prevent soda lime from drying out [Union information, 1999]:

- Change soda lime routinely according to the indicator or CO₂ measurement.
- Close the precision needle valves carefully after every anesthesia case.
- For those anesthetic devices not intended to be used for a long period of time, the absorber should be left empty after the device has been serviced.
- When drying out the breathing system and the respirator, the absorber, filled with soda lime, has to be removed from the system and sealed using the appropriate air-tight covers.
- It is **not** advised that the soda lime be moistened by pouring water over it or spraying it with water.

Changing the chemical make-up of Drägersorb 800 Plus, available since the beginning of 1999, has allowed the development of undesired by-products like Compound A and carbon monoxide to be greatly reduced.

3.3 Intravenous Anesthesia

Numerous clinics and hospitals prefer to use intravenous methods, with continuous intravenous injections of anesthetics, for administering anesthetics and maintaining depth of anesthesia. One of the reasons for this is that personnel in the operating room cannot be exposed to volatile anesthetic agents during mask anesthesia or from leaking endotracheal tubes. Other reasons being discussed are the advantages of increased safety and the more rapid induction associated with intravenous anesthesia, as well as fewer incidents of excitation and laryngospasms.

One of the hypnotics most frequently used for intravenous anesthesia is Propofol (Disoprivan[®]). Anesthetists who use Propofol must, however, take the following into consideration: dosages for children and adults differ greatly because children have smaller amounts of fat and muscle—this corresponds to their weight—and lower levels of plasma protein. An infusion of approximately 3 to 5 mg/kg is used for pediatric anesthesia induction and around 5 to 15 mg/kg/h for maintaining depth of anesthesia.

Some of the side effects of Propofol described are pain of injection, lowered blood pressure, and bradycardia. The frequency of bradycardia incidents in children is about 10 to 20 % higher than in adults. These side effects can be important when one considers that the cardiac output of infants and small children is mainly controlled by their heart rate and that baroreceptor functions are not yet marked.

Propofol, available since 1989, is only authorized for use for patients older than three years although, up till now, neither pharmacodynamic nor pharmacokinetic reasons have been presented supporting the restriction of authorization for patients under three years. Extensive research supports this assertion [Reinhold, 1998]. In addition to Propofol, there are several other hypnotics to choose from for intravenous anesthesia; these can also be combined with fast-acting analgesics and sedatives (see Table 12).

When would one use intravenous anesthesia on children instead of inhalation anesthesia?

Intravenous anesthesia is preferred to inhalation anesthesia in the following cases:

- for children with gastric content
- for children at higher risk of pulmonary aspiration of gastric contents
- in those cases where malignant hyperthermia is suspected; Propofol is not a triggering factor
- for bronchoscopic operations
- for repeated anesthetic administration
- for neurosurgical operations causing increased intracranial pressure

Table 12: 32 to 64 combinations for TIVA (total intravenous anesthesia) [Kraus, 1998]

analgesic	sedative	hypnotic
Fentanyl	DHBP	Trapanal
Alfentanyl	Midazolam	Methohexital
Sulfentanil	Flunitrazepam	Propofol
Cetamin	Diazepam	Etomidate

3.4 Muscle Relaxants

The pharmaceutical kinetics and dynamics of muscle relaxants in children differ considerably from those in adults.

- A larger distribution volume leads to lower plasma levels despite an equal dosage of muscle relaxants.
- Motor endplates and contractile elements of the muscle cells are at different levels of maturity and the release of acetylcholine is limited.
- The time it takes muscle relaxants to become effective in children varies greatly.
- The elimination of muscle relaxants takes place more slowly due to immature kidneys and liver.
- Muscle fatigue has been observed in infants younger than 2 months, even without the presence of muscle relaxants [Diefenbach, 1998].

Succinylcholine

Succinylcholine is used for endotracheal intubation. In order to obtain the same degree of relaxation, children need higher doses of fast-acting depolarizing relaxants than adults because of their weight. Infants are given infusions of 2 mg/kg and older children 1.5 mg/kg.

Administering succinylcholine to children can lead to life-threatening complications like bradycardia, asystole, stiff muscles, and muscle fiber decomposition with myoglobinemia and malignant hyperthermia.

Non-depolarizing Muscle Relaxants

Non-depolarizing muscle relaxants are used on pediatric patients for intra-operative muscle relaxation. They are also increasingly used for endotracheal intubation. Children are, however, very sensitive to non-depolarizing muscle relaxants and can easily be accidentally overdosed.

Table 13: Muscle relaxants
[Altmeyer, 1996]

	dosage for intubation (mg/kg)	repeated dosages (mg/kg)	length of effectiveness (min)	side effects
Pancuronium (Pavulon®)	0.08 to 0.1	0.02	30 to 45	tachycardia
Vecuronium (Norcuron®)	0.1	0.02	15 to 20	
Atracurium (Tracrium®)	0.3 to 0.5	0.1	15 to 20	occasionally anaphylactoid reactions
Alcuronium (Alloferin®)	0.2 to 0.3	0.05 to 0.1	30 to 40	decreased blood pressure
Rocuronium (Esmeron®)	0.6	0.1	25 to 30	
Mivacurium (Mivacron®)	0.25	0.1	5 to 13	

4. Anesthesia Accessories



A large assortment of anesthesia accessories, specially made to meet the needs of children, is available for all sorts of use.

4.1 Masks

The masks used for anesthetic induction, the recovery phase and mask anesthesia in general have to fit the patient according to age (see Table 14). Requirements for pediatric masks include a minimum of dead space between the face and the mask, light weight and the ability to be sterilized repeatedly. Rendell-Baker masks fulfill these requirements exceptionally because the inside of the mask is almost completely filled by the child's face. The dead space factor for the smallest size is about 2 to 4 ml.

When is intubation preferred to mask anesthesia for pediatric anesthesia?

Mask anesthesia is most often the preferred method for short operations, but should not be used for:

- high-risk patients
- patients with gastric content or when gastric content is suspected
- operations of a duration longer than 30 minutes
- special positions (e.g. stomach or side positions, etc.)
- operations on the throat, or throat and nose region
- children with sepsis

Table 14: Masks

age	mask size	dead space (ml)
premature infants	0	2
neonates	1	4
1 to 3 years	2	8
4 to 8 years	3	15

4.2 Tubes

Auxiliary equipment for respirators includes throat, tracheal and nasopharyngeal tubes.

Throat Tubes

The Guedel tube, oropharyngeally inserted, helps keep the respiratory tract open and is available for pediatric patients in three different sizes. It should be noted that by using a Guedel tube which is too small, the root of the tongue could drop backwards. If a Guedel tube which is too large is used, the epiglottis could be closed off from the trachea.

Tracheal Tubes

Thin-walled non-recyclable tubes made from PVCs are often used for pediatric endotracheal tubes. In order to prevent cuff pressure from damaging the tracheal mucus membrane, only uncuffed tubes are used on children aged 8 or younger. In emergency situations, the throat is enlarged with the aide of special wadding, or the next larger size is used.

Air leakage during ventilation should be less for those tubes without cuffs. Leak rates for any given tube should be within a range of 10 to 20 % of the applied minute volume, and if respiratory pressure values are >20 mbar, the anesthetist should be able to hear the sound of leakage. If there is no leaking noise, a smaller tube should be used [Eberhard, 1998].

The black mark on the tip of the tube indicates how deep intubation should be; the mark should be positioned below the vocal chords.

Generally speaking, tubes are described by two different sizes, I.D. and O.D. (or Charrière). I.D. indicates the inside diameter in mm and O.D. indicates the outer diameter in mm, also called Charrière. Tube sizes for children aged 1, or respectively 2, and older is calculated as follows:

$$\text{Outer tube diameter (Ch)} = 18 + \text{age} \quad (> 1 \text{ year})$$

$$\text{Inside diameter (mm)} = (\text{age} + 16)/4 \quad (> 2 \text{ years})$$

The rule of thumb is that the tube should be as large as the small (pinky) finger or nostril of the child.

age	weight (kg)	inside diameter (mm)	outer circumference (Ch)
premature infants	< 2.5	2.5	12
neonates	2.5 to 5	3	14
6 months	5 to 8	3.5	16
1 year	8 to 10	4	18
2 to 3 years	10 to 15	4.5	20
4 to 5 years	15 to 20	5	22

Nasopharyngeal Tubes

These tubes can be positioned either orally or nasally (see Table 16). Nasopharyngeal tubes used for nasotracheal intubation are made of soft rubber or plastic. After being moistened with a lubricant, a nasotracheal tube is inserted through the lower nasal passage, pushed into the pharynx, and then secured.

advantages	disadvantages
nasotracheal intubation	
<ul style="list-style-type: none"> more reliably secured in position tip of tube less often dislocated easier for postoperative ventilation easier to care for 	<ul style="list-style-type: none"> damage to nasopharyngeal structures during insertion pressure ulcers on nostrils when used for long-term ventilation
orotracheal intubation	
<ul style="list-style-type: none"> simple less, or no trauma standard use 	<ul style="list-style-type: none"> less reliably secured accidental intubation large amount of intratracheal movement of tip of the tube pressure points on hard and soft palate and back pharynx wall when used for long-term ventilation

Table 16: Advantages and disadvantages of nasotracheal and orotracheal intubation [Grüneß, 1995]

4.3 Laryngeal Masks

Laryngeal masks have found world-wide acceptance, even in pediatric anesthesia. They represent a compromise between face masks and endotracheal intubation. As is the case with endotracheal intubation, the hands of the anesthetist are free to perform other tasks, but mucus membranes in the larynx and trachea are not irritated (see Table 17). These masks are inserted under inhalation anesthesia or after intravenous anesthesia induction. After the correct position has been obtained, the cuff is filled with air until there is no leakage. Monitoring is done acoustically: a respiratory pressure value of 20 mmHg should not produce any sound of leakage.

Chapter 7.3 describes in detail how laryngeal masks are used.

advantages	disadvantages
<ul style="list-style-type: none"> • alternative for tracheal stenosis • less invasive than endotracheal intubation (every intubation leads to subepithelial edema, microbleeding, etc.) • less coughing, pressing, and choking induced during the extubation phase • less respiratory tract resistance than with endotracheal intubation • anesthetist's hands free for other tasks • reliable upper respiratory tract opening • also helpful during difficult intubation because the mask ventilates, allowing a tube to be positioned with the help of fiber optics 	<ul style="list-style-type: none"> • does not completely protect against aspiration • does not protect the airway as well as a tube • not reliable for respiratory pressure higher than 20 mmHg • tracheal suction is difficult • as is the case for endotracheal intubation, experience is necessary • if the cuff is over-inflated: recurrent paresis, ulcers in the pharynx

Table 17: Advantages and disadvantages of laryngeal mask usage

What are the advantages and disadvantages of laryngeal mask usage?

5. Ventilation in Pediatric Anesthesia



Choosing the most suitable form of ventilation ensures the most gentle treatment possible.

5.1 Mechanical Modes of Ventilation

All known ventilation modes used in pediatric anesthesia come from adult anesthesia. These modes include the conventional forms of ventilation, IPPV and SIMV, as well as the latest, PCV.

5.1.1 The Ventilation Mode IPPV

IPPV (intermittent positive pressure ventilation) is a time-cycled volume-controlled ventilation mode. During this form of controlled ventilation, the respirator delivers a preset volume and a constant inspiratory flow. Time and frequency are given. The patient does not breathe on his/her own.

The pressure which develops inside the breathing system and the lungs is derived from both the set parameters, and the resistance and compliance of the patient's lungs.

Pressure monitoring is of great importance in order to avoid high peaks of pressure. Dräger anesthetic machines protect against these unwanted pressure peaks by allowing the anesthetist to set a maximum pressure limit, P_{max} , which cannot be exceeded.

IPPV is primarily used on those patients with healthy lungs and ensures that the patient constantly receives a defined minute volume.

Figure 12: Pressure and flow curves during IPPV

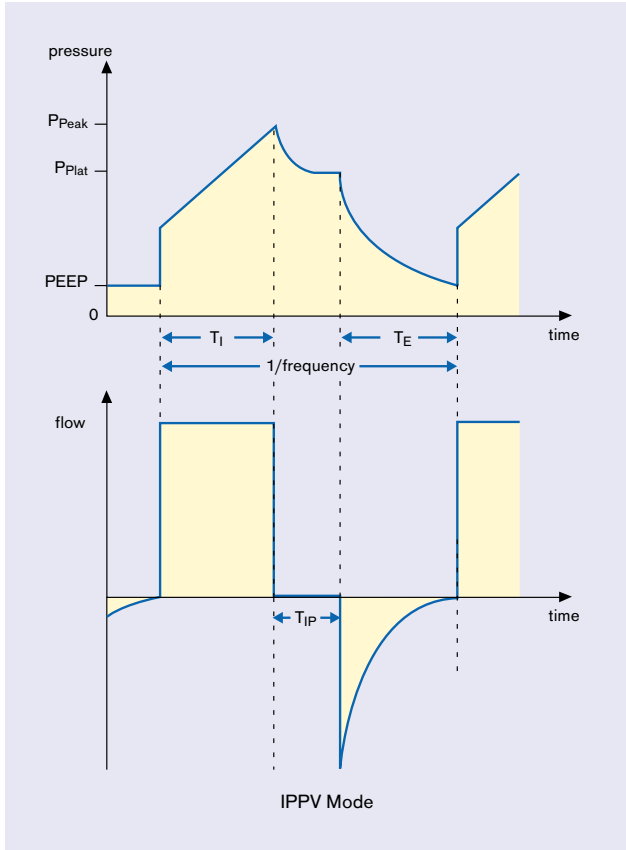

5.1.2. The Ventilation Mode SIMV

SIMV (synchronized intermittent mandatory ventilation) is a mixture of spontaneous breathing and controlled ventilation in which the respiratory strokes of the respirator are synchronized with those of the patient. The patient is able to breath spontaneously in regular, predetermined intervals. Mandatory ventilation strokes ensure that a minimum in ventilation is fulfilled within these intervals. Mechanical respiratory strokes are triggered by the patient; that means they take place within a timeframe anticipated by the patient and his/her inspiratory efforts, not during the unsynchronized delivery of respiratory strokes. SIMV is used in pediatric anesthesia, for instance, during the recovery phase.

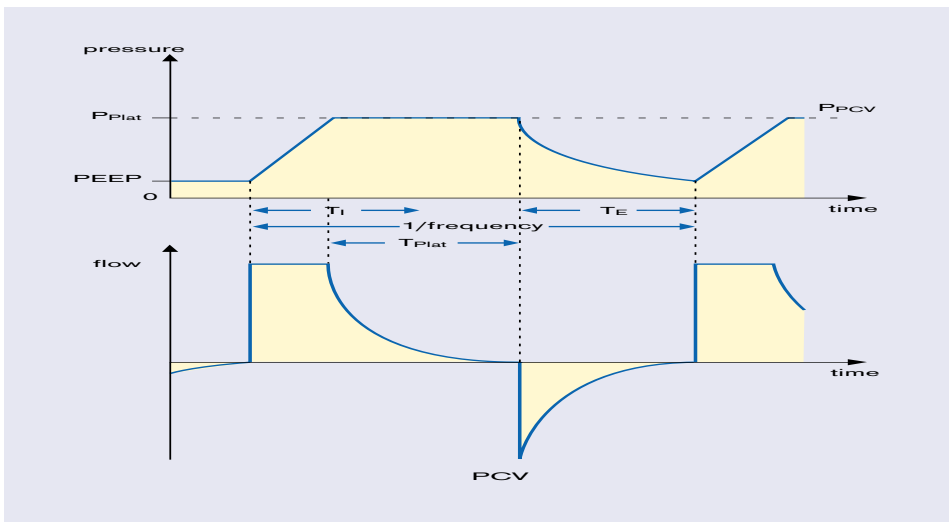

Figure 13: Pressure and flow curves during SIMV

Are the latest anesthetic machines able to ventilate using a pressure-controlled ventilation mode (PCV)?

5.1.3 The Ventilation Mode PCV

In addition to volume-controlled ventilation, the latest anesthetic machines from Dräger come with a pressure-controlled ventilation mode. Pressure-controlled ventilation (PCV) is not, however, the successor to volume-controlled ventilation. It is ideal not only for adult anesthesia, but for general use in pediatric anesthesia as well. The lungs of children are susceptible to overinflation during anesthesia. Reasons for this include insufficient flexibility of the alveoli, shallow breaths and an elastic thorax.

Having a set maximum pressure, which makes it possible to limit the amount of pressure going into the respiratory tract, minimizes the risk of barotrauma and helps avoid pressure peaks. Barotrauma could occur during IPPV as a result of an inspiratory flow which is too high, secretion deposits, or bronchospasm.

What are the advantages of pressure-controlled ventilation over volume-controlled ventilation?

The major advantage of PCV over volume-controlled modes (IPPV) in conventional partial rebreathing systems is in being able to use uncuffed endotracheal tubes for neonates and small children, which allow large amounts of leakage (> 20 % of the minute volume). By increasing the flow to maintain the set pressure, losses caused by leakage are automatically compensated for to a certain degree. But not only is tube leakage counteracted, leakage caused by the lungs (e.g. lung fistulas) are also counteracted.

In addition, gas distribution disorders within the lungs can be better compensated for in PCV than in IPPV.

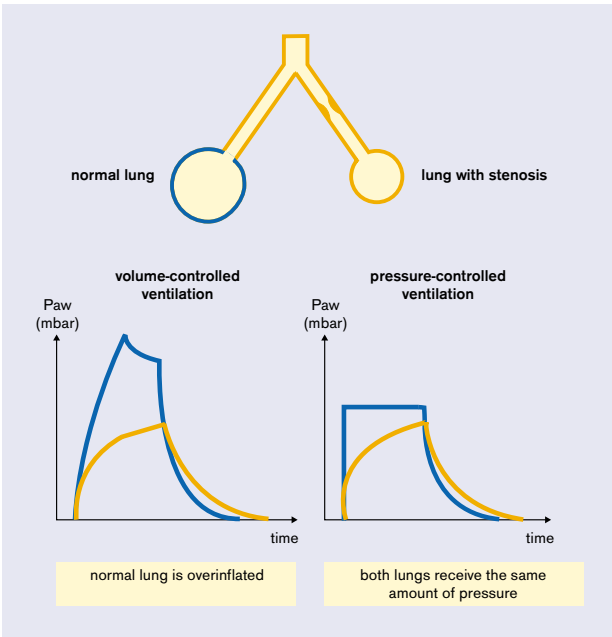
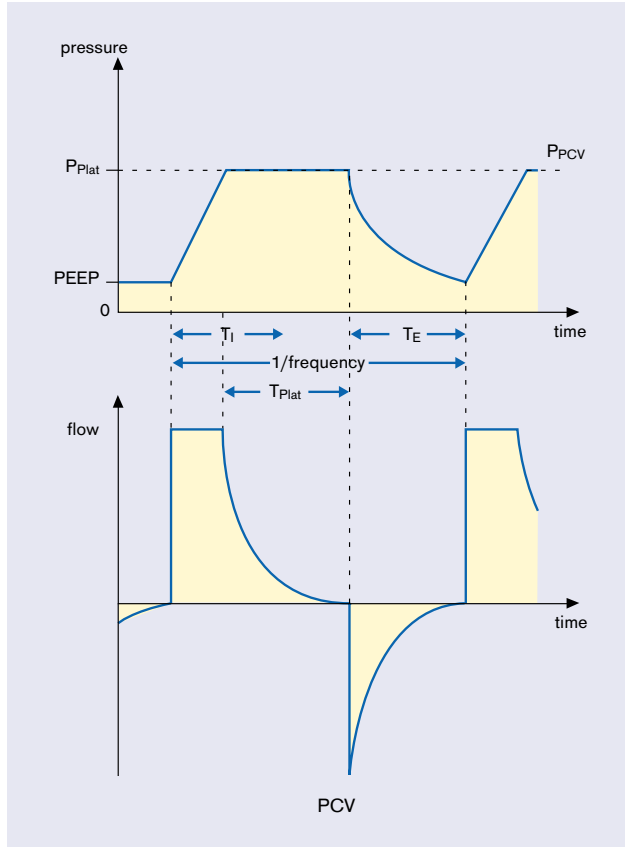

Figure 14: Different effects on inhomogeneous lungs during ventilation in the volume and pressure-controlled ventilation mode

If the lungs are inhomogeneous, conventional volume-controlled ventilation overinflates the normally healthy lung and underinflates the obstructed areas (see Figure 14). This results in temporary pressure differences in and different levels of volume throughout the lungs, which are exposed to great mechanical loads.

PCV ensures that the lungs fill more evenly and that the healthy lung is not damaged by excess pressure.

Figure 15a: Pressure and flow curves in PCV



Today's Dräger respirators initially deliver constant inspiratory flow, and do so until the PCV pressure limit has been reached. The inspiratory flow is then decelerated for the rest of the inspiratory phase (see Figure 15a). Since pressure is constant, the more the lung fills, the more the inspiratory flow decreases. At the end of inspiration, pressure in the lungs equals the pressure in the breathing system and there is no more flow.

The Dräger pressure-controlled ventilation mode distinguishes itself from that of other manufacturers in that it offers variable inspiratory flow setting. This feature allows the inspiratory flow to be set as low as possible in order to provide the most homogeneous ventilation possible. Low flow rates produce less turbulence and thus, provide better gas distribution.

The volume delivered in PCV is not set directly, it is derived from the set pressure (P_{PCV}^*), the level of PEEP and the patient's lung compliance in a linear volume-pressure range:

$$V_{pat} = C_{pat} (P_{PCV} - PEEP)$$

Every individual change in pressure or level of PEEP changes the tidal volume (see Figure 15b and 15c).

* Respiratory pressure is marked as the absolute Pmax in the Julian anesthetic workstation and as the relative dPi (pressure difference above PEEP) in PhysioFlex.

That means:

- An increase in PEEP with a fixed P_{PCV} reduces the volume. Volume only remains constant if PEEP and P_{PCV} are changed simultaneously.
- The amount of volume delivered is influenced by each and every change in compliance which occurs, e.g. as a result of physical movement, opening the thorax, the effects of medication, or varying lengths of ventilation. This increases the importance of monitoring the expiratory volume.

It is important to note that a variation in the inspiratory flow can lead to a decrease in tidal volume if the set flow does not reach the pressure limit (see Figure 15d). A change in frequency on the device does not lead to tidal volume deviations provided that the expiratory phase is long enough and that the inspiratory flow is large enough to reach the plateau curve needed to drive PCV.

If PCV is used on the anesthetic workstation PhysioFlex, a few minor differences in philosophy should be noted as compared to other Dräger anesthetic machines. Ventilation parameters for PCV on this device include the set respiratory pressure dP_i , the tidal volume minimally required (V_T min), frequency, the I:E ratio and PEEP. The course of the inspiratory phase does not need to be set by the user, the system calculates this from dynamic lung compliance.

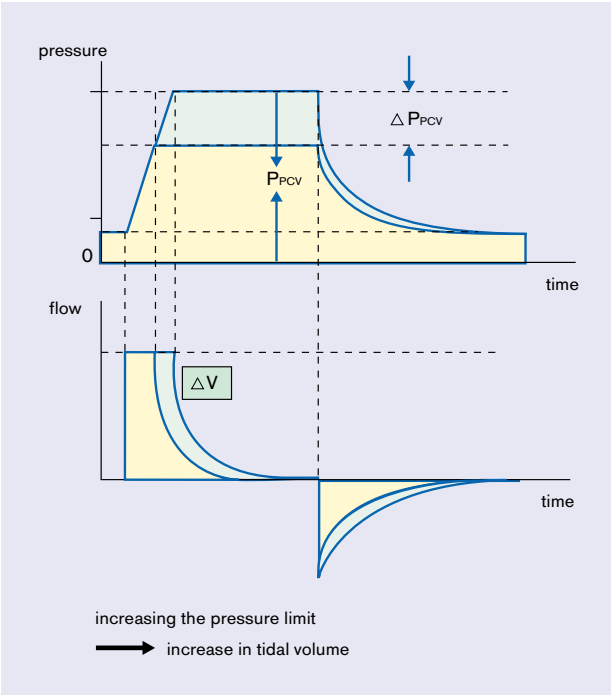
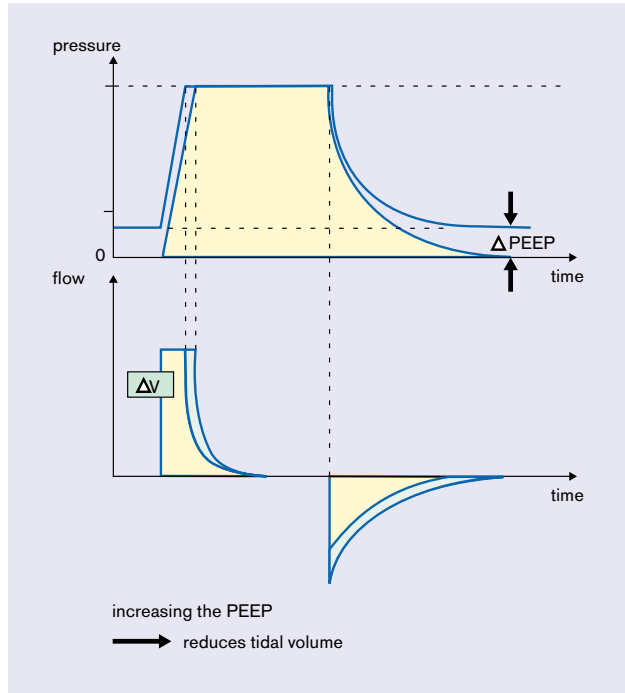

Figure 15b: Increasing only the pressure limit without simultaneously increasing the PEEP level causes the tidal volume to increase

Figure 15c: Increasing the PEEP level without simultaneously increasing the pressure limit causes the tidal volume to decrease



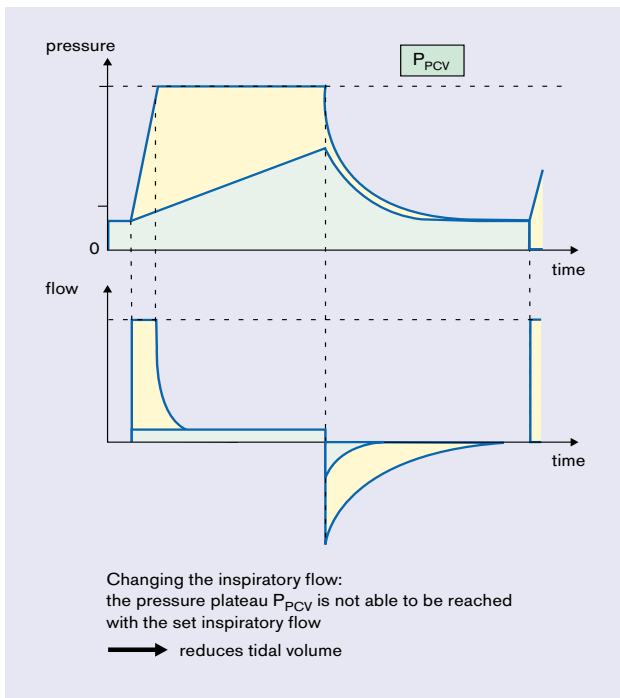

Figure 15d: Decreasing the inspiratory flow so that the set flow can no longer reach the pressure limit leads to a decrease in tidal volume

Table 18: Comparing IPPV and PCV [Rupp, 1999]

	controlled ventilation	
characteristics	passive patient (e.g. relaxed) respirator takes over the work	
control	time-time control inspiratory and expiratory phase fixed	
mode	IPPV volume-controlled ventilation (intermittent positive pressure ventilation)	PCV pressure-controlled ventilation (pressure-controlled ventilation)
most important parameter	tidal volume V_T	pressure P_{pcv}
pressure curve	Figure 12	Figure 15a
flow-characteristics	constant inspiratory flow	decelerating inspiratory flow
results	pressure build-up according to patient compliance $P_{plat} - PEEP = V_T / C_{Pat}$	maintained volume according to patient compliance $V_{Pat} = C_{Pat} (P_{PCV} - PEEP)$
risks	pressure P_{Peak} which is too high; pressure monitoring required	volume V_{Pat} too low or too high; volume monitoring required

5.2 Ventilation Parameters

In order to maintain or to improve the pulmonary gas exchange of a child, the initial ventilation parameters must be adjusted to each given situation on the various anesthetic workstations (see Tables 19 and 20).

Which ventilation parameter settings should be selected for which age group?

Alveolar ventilation and thus, pulmonary gas exchange, can be improved by using high *tidal volumes* with correspondingly low *respiratory frequencies*. At the same time however, the rise in mean respiratory pressure must be monitored since it can have negative effects on the circulatory system and alveolar perfusion. By increasing the respiratory rate and maintaining minute volume, dead space ventilation increases. Infants are usually ventilated with a frequency of 20 to 30/min and small children with a frequency of 15 to 20/min. In volume.-controlled ventilation, tidal volume can be set directly, while in pressure-controlled ventilation the desired tidal volume is influenced by the patient's respiratory characteristics (compliance) and by pressure (see Chapter 5.1, Mechanical Forms of Ventilation).

Tidal volumes of 4 to 6 ml/kg for premature infants and 6 to 8 ml/kg for neonates are recommended. Tidal volume settings are monitored, among others, by the resulting etCO_2 and capillary CO_2 values which should be around 35 to 40 mmHg.

As several studies have shown, the use of high peak pressures is more advantageous for lungs with poor compliance than the use of high tidal volumes. The latter can easily lead to the tearing of individual elastic alveoli [Bancalari, 1980].

Figure 16: Effects on oxygenation and ventilation

Improving oxygenation (p_aO_2) by

- increasing the inspiratory oxygen concentration (FiO_2)
- increasing mean airway pressure by
 - increasing PEEP in PCV/IPPV
 - lengthening the inspiratory phase in PCV/IPPV
 - increasing plateau pressure in PCV
 - increasing inspiratory flow in IPPV

Improving ventilation (p_aCO_2 decrease) by

- increasing minute volume (MV) by
 - increasing frequency
 - increasing tidal volume
 - optimizing form of ventilation
 - adequate I:E ratio
 - adequate inspiratory flow

The *I:E ratio* should be between 1:1 and 1:2 for uncomplicated cases of artificial respiration. If oxygen exchange disorders are present (e.g. ARDS), pediatric patients can be ventilated like adult patients using an inverted I:E ratio and a low inspiratory flow (inverted ratio ventilation). In this case, a change in the I:E ratio affects the mean respiratory pressure and, in conjunction with FiO_2 , oxygenation. To avoid unintentional alveolar PEEP (air trapping), the expiratory flow curve should be monitored closely so as not to exceed the minimum expiratory phase.

Many research projects have shown that short inspiratory phases with high peak pressures of up to 35 mbar are less likely to cause barotrauma than long inspiratory phases (> 0.6 sec) with low pressures.

Physiologically, premature infants and newborns build up a physiologic PEEP in the larynx area during expiration which is then eliminated by intubation. By setting the *positive end-expiratory pressure (PEEP)*, the risk of bronchial collapse which is easily triggered by high closing volume—is reduced. Short expirations phases (caused by “inverted ratio ventilation,” or high respiratory frequencies) also generate automatic PEEP. PEEP does not trigger atelectasis, instead it keeps the alveoli which have been re-opened through high inspiratory pressure or through prolonged inspiratory phases from collapsing again. In addition, PEEP helps increase the functional residual capacity (FRC).

In a study of Motoyama, ventilating with a PEEP of 5 mbar increased the FRC of intubated or anesthetized infants by 28 % as compared to ventilating them without PEEP.

Depending on the child’s oxygenation level, PEEP pressure is set to between 4 and 8 mbar and, in extreme situations, to 10 mbar. Higher levels are not normally tolerated by pediatric patients. Changing the setting should take place in increments of 1 to 2 mbar. One side-effect of ventilating with PEEP is the disruption of the cardiac and circulatory systems, e.g. a decrease in cardiac output due to a lessening in venous return flows and cardiac compression.

For cases of heart defects with minimum pulmonary blood circulation, a PEEP of > 2 mbar should be avoided. In addition to this, there is also the risk of overinflating the alveoli of damaged lungs with varying areas of distribution (e.g. bronchial stenosis).

Does it make sense to use PEEP, on principle, for each and every case of newborn ventilation?

Peak pressures affect alveolar ventilation via $p_a\text{CO}_2$ during artificial respiration and depend on resistance, compliance, inspiratory flow and tidal volume. Pressure limiting is of utmost importance in volume-controlled ventilation modes to reduce the risk of alveolar overinflation. Peak pressure should not be set higher than 20 to 25 mbar. Peak pressures of > 35 mbar should be avoided altogether since the risk of brain hemorrhage increases [Bancalari, 1980]. Peak pressures of between 6 and 8 mbar are usually sufficient for ventilating premature infants under 1000 g. Changes to the setting should be made in increments of 2 mbar.

While the *inspiratory flow* is regulated directly in pressure-controlled ventilation modes, it can only be indirectly regulated in IPPV through the I:E ratio, $T_i:T_e$ and the respiratory rate. If, during pressure-controlled ventilation, the inspiratory flow chosen is too low, the desired volume cannot be delivered in the preset time and artificial respiration will be insufficient. The steepness of the rise in pressure increases in IPPV as the inspiratory flow increases, and peak pressure increases simultaneously. In order to protect small pediatric patients, a stenosis alarm is triggered whenever respiratory pressure reaches the set upper limit. Usually, an inspiratory flow of 4 to 10 ml/min is sufficient for infants.

The following sentence supports a theory about maintaining *inspiratory oxygen concentrations* in pediatric anesthesia: *keep it as low as possible, but as high as necessary*. The concentration should be set so that the p_aO_2 values for infants are lower than 70 mmHg. P_aO_2 values which are larger than 70 mmHg promote retinas of prematurity in premature infants (see Chapter 2.1.7).

	infants (5 kg)	small children
respiratory rate	20 to 30/min	15 to 20/min
I:E ratio	1:2	1:2
inspiratory pressure limit	< 20 mbar	< 20 mbar
PEEP	3 mbar	3 to 5 mbar
FiO ₂	0.5	0.5
tidal volume	10 to 15 ml/kg KG	10 to 15 ml/kg KG

Table 19: Initial respirator settings in IPPV

	premature infants (2 kg)	infants (5 kg)	small children
pressure limit (mbar)	16 to 18	25	25
frequency (1/min)	30 to 60	20 to 30	15 to 25
I:E	1:2	1:2	1:2
PEEP (mbar)	2	2	2
inspiratory flow (l/min)	4 to 6	4 to 8	4 to 12

Table 20: Initial respirator settings in PCV

5.3 Breathing Systems

The breathing system represents the link between the anesthetic machine and the patient, providing the latter with fresh gas. There are open, non-rebreathing, partial rebreathing and complete rebreathing systems, but only the last three are of meaning for anesthetic workstations. Non-rebreathing systems are also divided up into flow-controlled and valve-controlled systems.

Table 20: Initial respirator settings in PCV

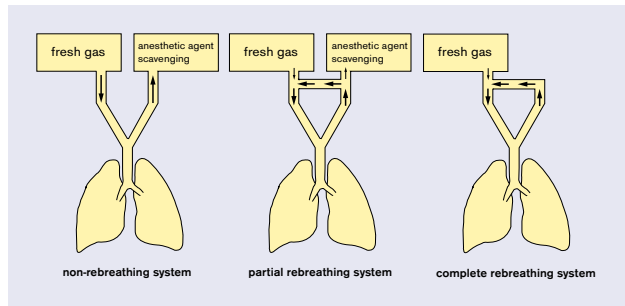

5.3.1 Flow-controlled Non-rebreathing Systems

Various kinds of breathing systems are used in pediatric anesthesia. Different flow-controlled non-rebreathing systems on the market include modifications of the so-called Ayre T-piece, like the Kuhn System, the Bain System and the Jackson-Rees System. These non-rebreathing systems are characterized by the fact that they have neither non-rebreathing valves nor apparatus for absorbing carbon dioxide, part of the expiratory gas. These systems are simple and light-weight, they have little dead space and, because they do without inspiratory and expiratory valves, there is a minimum of airway resistance.

The biggest problem with these systems is a high fresh-gas flow, which has to be kept high in order to be able to prevent the possibility of rebreathing. If the fresh-gas flow is too low, CO₂ can accumulate in the expiratory hose during expiration and be taken up by the patient during the inspiratory phase. It is recommended that the fresh-gas flow be 2 to 3 times higher than the estimated minute volume (see Table 21).

What usage problems are associated with non-rebreathing systems?

These systems are only used for infants and small children because the fresh-gas consumption of older children is connected with a higher degree of risk to OR personnel and thus, not tolerable [Altemeyer, 1993].

Many anesthesiologists feel that the high fresh-gas flow, active in addition to the actual tidal volume, is problematic. Studies from Wawersik and Schreiber show that the use of non-rebreathing systems for anesthetic ventilation almost always leads to hyperventilation with a carbon dioxide partial pressure of < 30 mmHg [Wawersik, 1976] or 18 to 25 mmHg [Schreiber, 1994].

Other difficulties include the absence of things like humidification and warming for anesthetic gases, anesthetic gas suction systems, and monitoring for ventilation parameters. These disadvantages can be reduced only by using costly auxiliary equipment.

Ayre T-piece

The Ayre T-piece was first described in 1937 by Philip Ayre and was initially used exclusively for maintaining spontaneous breathing. The principle behind the T-piece is based on the switching behavior of a T-piece placed between the fresh-gas supply tube and the breathing mask or tube. The open section comes in contact with ambient air. Fresh gas and ambient air flow to the patient during inspiration. During expiration, fresh gas and exhaled CO_2 is carried away.

Figure 18: Ayre T-piece

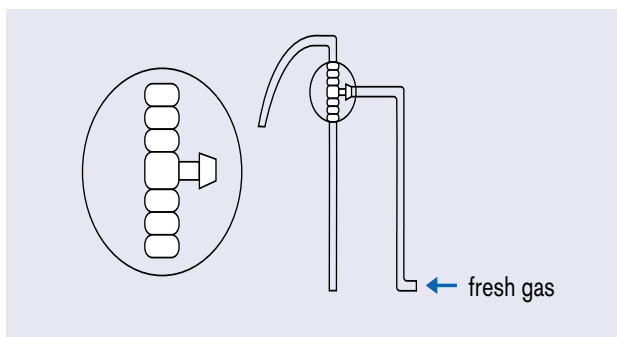

Jackson-Rees System

This system represents the first modification of the T-piece. The expiratory hose was lengthened and has a bag on one end with an opening. This construction allows system volume to become greater than tidal volume in pediatric patients. During spontaneous breathing, system is comparable to the T-piece. Assisted ventilation is performed by closing the open end of the bag with the thumb and forefinger and compressing the bag.

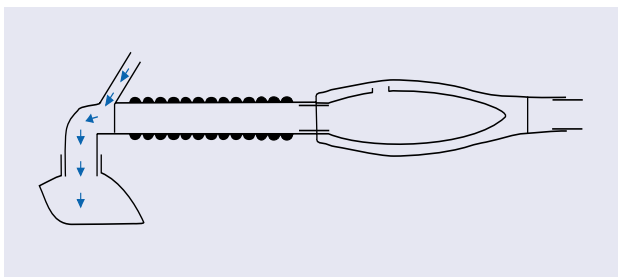

Figure 19: Jackson-Rees system

Kuhn System

The Kuhn system can be used for both spontaneous breathing and for manual anesthetic ventilation. Compared to the Jackson-Rees system, the Kuhn system has less apparatus dead space (there is a special fresh-gas supply tube guide in the corner piece) and less flow resistance during expiration. The system should only be used on children weighing less than 15 kg. The anesthetic workstations Cicero EM, Cato and Julian from Dräger also provide this form of manual ventilation in a non-rebreathing system; they also monitor respiratory pressure, the delivered O₂ concentration and —if possible— the concentration of anesthetic gases. The system has two advantages: the possibility of quickly adjusting the gas concentration delivered and little expiratory resistance.

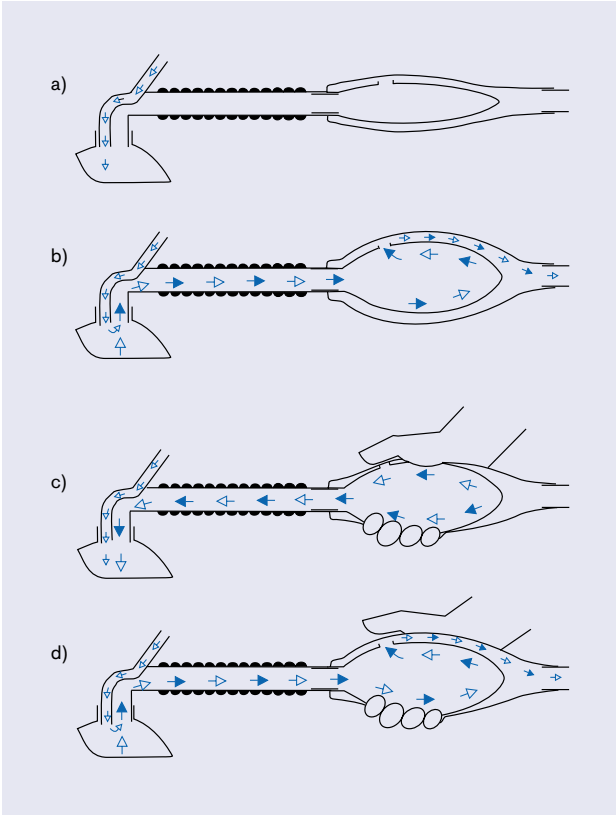

Figure 20: Spontaneous breathing in the Kuhn system, the inspiratory phase (a): fresh gas flows through the fresh-gas supply tube to the patient
The expiratory phase (b): expired gas and fresh gas flow into the breathing bag, part of it escapes to atmosphere
Manual ventilation, the inspiratory phase (c): closing the opening of the breathing bag with thumb and forefinger, and compressing the bag lightly induces a flow of fresh gas and anesthetic gas mixture from the bag to the patient
The expiratory phase (d): releasing the closed-off opening, and the flow of expired gases and fresh gas into the bag
[Larsen]

Bain System

The principle behind the Bain system, which is the preferred system in Anglo-American countries today, is based on running the fresh-gas supply tube co-axially inside the expiratory hose. Advantages of the Bain system, which can be used for both spontaneous breathing and controlled ventilation, include easy handling and the scavenging of excess anesthetic gases. This system is not limited to pediatric anesthesia, it can be used universally. Two disadvantages of the system are large fresh-gas consumption and the insufficient humidification of breathing gases. For those anesthesia cases lasting longer than one hour, the Bain system should be additionally equipped with humidification and pre-warming equipment for the fresh gas.

The modified Bain system from Dräger provides for these ventilation parameters with the addition of an oxygen sensor and a manometer.

Figure 21: Bain system

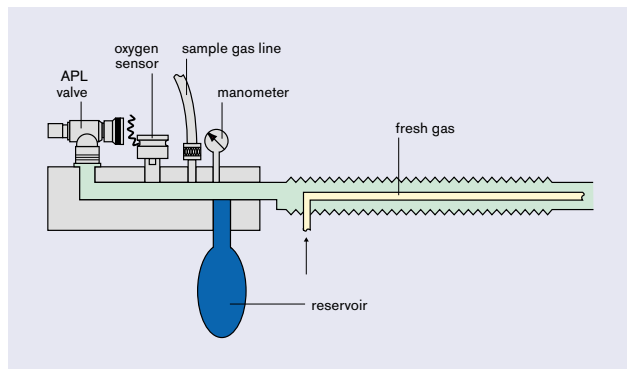

Connecting Dräger Anesthetic Workstations and Non-rebreathing Systems

Non-rebreathing systems may be connected to the external fresh-gas outlet of the anesthetic workstations Julian and Cato. In addition, the anesthetic workstation Cicero EM, as well as Cato, offer the possibility of connecting these systems to external fresh gas through the inspiratory outlet. All gas concentrations, inspiratory and expiratory, are measured, while respiratory pressure and volume are monitored either not at all or only by adding additional equipment. At the same time, gas measurement and FiO₂ alarms are active. A pressure control valve prevents pressure peaks from occurring (max. 80 mbar).

non-rebreathing systems	spontaneous breathing	manual ventilation
Ayre T-piece	2 to 4 MV	2 to 3 MV
Jackson-Rees system	2 to 4 MV	1 to 2 MV
Bain system	200 to 300 ml/kg/min 2 x MV	100 ml/kg/min 2 x MV
Kuhn system	2 to 4 MV	2 to 3 MV

Table 21: Recommended fresh-gas flows for eliminating expired air

5.3.2 Valve-controlled Non-rebreathing Systems

One example of a valve-controlled non-rebreathing system is the Ambu-Paedi system. This system is known for the separation of inspiratory from expiratory air through a non-rebreathing valve placed close to the patient (Ambu valve). This valve allows expiratory air to escape to atmosphere. The valve has little resistance and minimal dead space, making the whole system quite suitable for use in pediatric anesthesia. This system does, however, also have two disadvantages: an absence of breathing gas humidification and an end-expiratory leakage, the latter of which makes it impossible to take an exact volume measurement [Altemeyer, 1993].

Figure 22: Ambu-Paedi system [Baum, 1998]

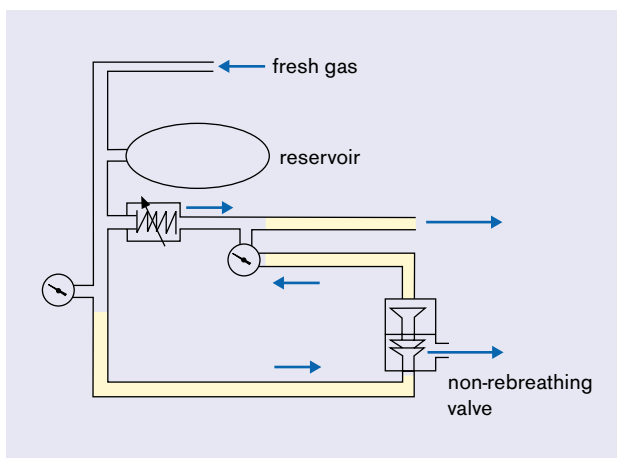

5.3.3 Partial Rebreathing Systems (Semi-closed Breathing Systems)

In a partial rebreathing system, part of the patient's expiratory air is channeled back after CO₂ has been absorbed and anesthetic gas added. At the same time, excess anesthetic gas is siphoned from the system. The amount of anesthetic gas removed from the system mainly depends on the set fresh-gas flow; as the fresh-gas flow increases, the rebreathing volume decreases and the volume of excess gas increases. In this case, the fresh-gas flow is larger than the uptake of the patient, but less than the patient's minute volume.

In order to use conventional adult circle systems for pediatric anesthesia, the adult circle system is modified with the Dräger pediatric breathing system (known by the name Ulmer Circle System [Altemeyer, 1993]) (see Figure 23).

The breathing hoses of the anesthetic machine are replaced with pediatric hoses for children weighing approx. 20 kg or less. The spiral or, respectively, Hytrel hoses found on the anesthetic workstation PhysioFlex are hardly elastic (little compliance) and have an inside diameter of 15 mm. The breathing bag has a volume of 0.5 liters. It is important to note that when the fresh-gas flow is very high and the inspiratory phase long, pressure, sometimes higher than expiratory pressure coming from the patient, can build up in the low-volume breathing bag. When the expiratory phase begins, pressure could peak due to this fresh-gas flow streaming out of the breathing bag. In order to avoid this situation, the fresh-gas flow should be reduced or a 1.5-liter breathing bag should be used.

Modified partial rebreathing, and complete rebreathing systems, have the following advantages over non-rebreathing systems:

- no time-consuming conversions
- integrated anesthetic gas scavenging
- no additional equipment for ventilating with warmed and humidified anesthetic gases
- optimal monitoring for ventilation parameters (see Chapter 5.6, Monitoring)
- reduced anesthetic gas consumption
- experience gained with present devices

Figure 23: Ulmer system

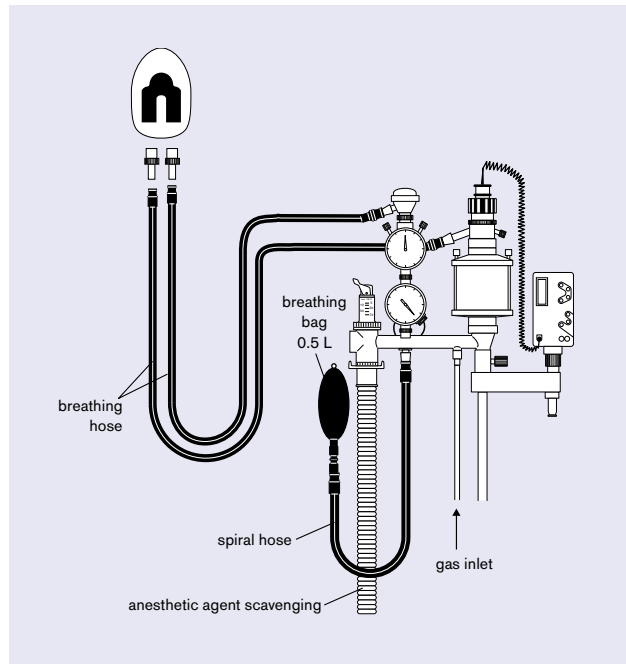

The effectiveness of non-rebreathing systems and pediatric circle systems has been compared in several studies. Stevenson, for instance, has varied inspiratory peak pressures, respiratory frequencies and lung compliance to show that, during pressure-controlled ventilation, the Bain system has no advantage over the circle system [Stevenson, 1999]. In another study, Schreiber researched the influence of the Kuhn system and the pediatric circle system on the oxygenation and ventilation of infants during mask or intubation anesthesia using transcutaneous p_aO_2 and p_aCO_2 measurements. This study went on to show that the type of anesthetic procedure influences oxygenation differently, but the circle system proved itself superior to the non-rebreathing system [Schreiber, 1994].

5.3.4 Complete Rebreathing Systems (Closed Systems)

In a complete rebreathing system, also known as a closed system, the total amount of gas expired from the patient is channeled back to the patient in the subsequent inspiratory phase after carbon dioxide has been eliminated from that gas. The fresh-gas volume corresponds to the amount of oxygen required for a child's metabolism and the amount of anesthetics taken in by the body (see Chapter 5.5.3, PhysioFlex).

5.4 Characteristics of Ventilation for Pediatric Anesthesia

5.4.1 Manual and Mechanical Ventilation for Neonates and Infants

Many publications describe neonates and infants as being better off with manual than with mechanical ventilation. Reasons given for this include the fact that an anesthetist's trained hand can more quickly detect changes in respiratory compliance than a machine can and that suitable respirators or the necessary respiratory monitoring is unavailable. A study from Spears simulated changes in respiratory compliance, like occlusions of the tracheal tube, on a test lung which was connected to either the Mapleson D system or a pediatric breathing system. This study proved that even experienced anesthetist's were not always able to identify these changes [Spears, 1991], but even the tiniest unidentified changes in compliance can lead to serious ventilation changes and disturbances in oxygenation for pediatric patients.

In comparison, mechanical ventilation maintains consistent ventilation while keeping the anesthetist's hands free for other important tasks.

The biggest advantage of volume-controlled ventilation (IPPV) over manual ventilation is the consistency of the volume delivered by the respirator. Even changes in patient compliance occurring, for instance, as a result of the operation can be compensated for by the anesthetic machine's so-called compliance compensation (see Chapter 5.4.3), thus avoiding a change in tidal volume. Large changes in compliance are reflected in a change of airway pressure and immediately displayed for the anesthetist.

Using pressure-controlled ventilation also means that various kinds of leakage will be identified and, usually, compensated for completely.

5.4.2 Respirator Requirements for Children

The goal of each and every ventilation case is to provide sufficient oxygenation (p_aO_2) and ventilation (p_aCO_2) with as little mean pressure as possible in order to protect lung tissue from damage. At the same time, healthy lungs should be protected from overinflation and collapsed lungs should be re-opened. This means that respirators have to meet many demanding requirements, especially in pediatric anesthesia. These requirements are best met by four of the latest Dräger anesthetic machines mostly used in adult anesthesia, but also in pediatric anesthesia. The anesthetic machines include the anesthesia workstations Julian, Cicero EM (US brand name Narkomed 6000), Cato and PhysioFlex.

Which features does an efficient pediatric respirator have?

- controlled/mechanical ventilation
- volume-constant, pressure-limited ventilation
- applicable low tidal volumes
- frequency variations: 6 to 60/min
- a variable I:E ratio
- PEEP up to 15 mbar
- sufficient breathing gas humidification and pre-warming
- low respirator compliance (> 0.5 ml/mbar)
- flow variance (4 to 20 l/min)
- alarms for disconnection and excess pressure
- monitoring for oxygen, pressure, volume, CO_2 and agent concentration

All of the above anesthetic devices from Dräger maintain volume-constant ventilation independent of respiratory rate, I:E ratio and fresh-gas flows by means of fresh-gas decoupling and compliance compensation [Schirmer, 1992 and 1994].

Many anesthetic machines from other manufacturers couple a change in fresh-gas flow, several ventilation parameters or patient compliance with a change in the tidal volume delivered by the respirator. This undesired influence is especially relevant for pediatric patients since it can lead to hypo- and hyperventilation if the error percentage of the delivered minute volume is very large.

Generally speaking, all respirators used for pediatric anesthesia should be equipped with at least a pressure limiting device to protect the sensitive lungs of pediatric patients. This requirement is met, for instance, by the anesthetic machine Fabius from Dräger.

5.4.3 The Fresh-gas Decoupler

The fact that fresh gas is not continuously admitted to the breathing system during the expiratory phase (fresh-gas decoupling) ensures that the applied tidal volume (V_T) is not influenced by the fresh-gas flow during the inspiratory phase. During the inspiratory phase, a valve ensures that fresh-gas delivery is decoupled from the patient.

Fresh gas is only fed into the breathing system of the anesthetic workstation Julian during the expiratory phase in IPPV. The anesthetic machines Cicero EM and Cato, on the other hand, store fresh gas in the reservoir during the inspiratory phase for the next respiratory stroke. Then, during the expiratory phase, this stored volume goes directly into the system. All breathing systems have a minute volume thus independent of the fresh-gas flow. In conventional breathing systems without fresh-gas decouplers, gas continually flows into the breathing system independent of inspiration or expiration. In addition to bag volume, fresh gas also flows to the patient during the inspiratory phase. When the fresh-gas flow decreases in a system without a fresh-gas decoupler, the set tidal volume decreases and the applied minute volume is reduced. This has a drastic effect on pediatric patients, because alveolar ventilation can be reduced by some 50 % (risk of hypoxia), although only about 30 % of the tidal volume is missing [Fösel, 1991].

If there is no fresh-gas decoupler and a high fresh-gas flow is set, the pressure curve continually rises, during the plateau phase, reflecting a rise in pressure and in this way acquires a second peak pressure (see Figure 24).

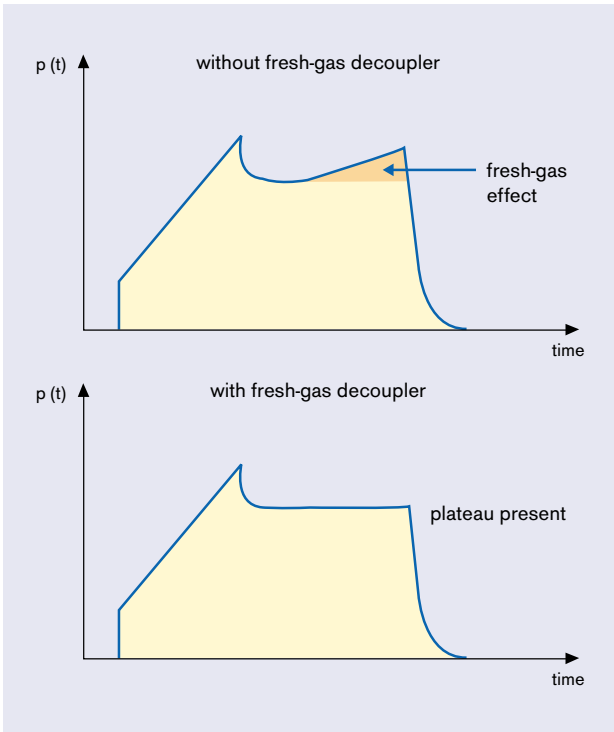

Figure 24: Effects of fresh-gas decoupling

5.4.4 Compliance Compensation

When ventilating premature infants and newborns with conventional respirators, large discrepancies can be seen between the set tidal volume of the device and that delivered to the lungs of the patient. This can have serious consequences for the already low pediatric tidal volumes.

A rise in inspiratory pressure compresses the gas within and expands the breathing hoses of those parts of the respirator which carry gas. This means that part of the tidal volume sent from the respirator to the system does not reach the pediatric patient. The level of this compressed volume depends on the compressed volume of the breathing system (absorber, hoses, bellows), on the proportion of internal device compliance to patient compliance, and on peak pressure (see Figure 25).

Dräger anesthetic machines carry out compliance compensation automatically and allow for volume lost in the breathing system and the hoses. This information is provided in the power-on self test of the devices, saving the anesthetist the trouble of having to calculate compliance and pressure values in order to apply the desired tidal volume. In addition, the anesthetist simultaneously receives leak information from the automatic leak test, carried out on the entire breathing system.

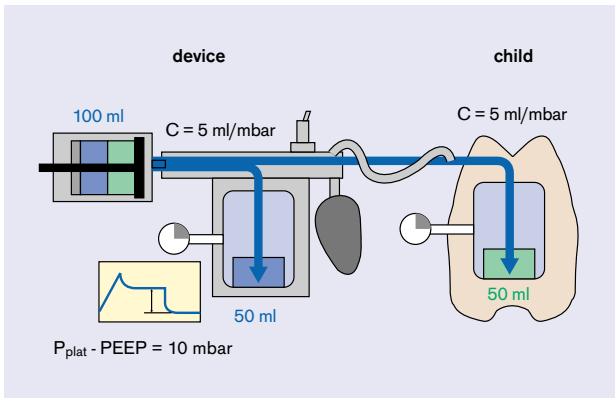

Figure 25: Compliance compensation [Jaklitsch, 1995]

The 100 ml delivered by the respirator is distributed evenly throughout the system because the device and the lungs have the same compliance (5 ml/mbar each). In this way, 50 ml reach the patient's lungs while the other 50 ml remain in the breathing system and the hoses. To achieve this, a pressure of 10 mbar is required.

Another important advantage of compliance compensation is the fact that intra-operative changes in pulmonary compliance, occurring e.g. as a result of secretion removal or extra-thoracic compression, are automatically compensated for during volume-controlled ventilation. Set minute volume continues to be applied regardless of outside influences.

How does dead space volume affect ventilation?

5.4.5 Dead Space Volume

Reducing dead space volume—that part of tidal volume which is not involved in the gas exchange—is an especially important concern when using anesthetic systems for pediatric anesthesia. Compared to adults, premature infants and newborns, especially, have a much more unfavorable ratio of tidal volume to dead space. Since a large portion of tidal volume is used for flushing the anatomical dead space (the airway up to where the alveoli begin), ventilating with too little tidal volume could mean that CO₂ is ineffectively exchanged despite this age group's high respiratory rate. The anatomical dead space for each respiratory stroke is 2 ml/kg. In addition to the anatomical dead space, physiological and apparatus dead space must also be taken into consideration. Physiological dead space refers to the alveoli ventilated but not perfused, and apparatus dead space includes the individual components of the device which are between the Y-piece and the alveoli. These individual components include the Y-piece itself, the tube, tube adapters, or the alternative to that, the mask. Apparatus dead space can increase even more with the use of filters (bacterial or HME filters, see Chapter 5.8, Breathing Gas Conditioning) or, if the anesthetic machine is from another manufacturer, flow sensors or capnography sensors (see Chapter 5.6.6, Capnography). Thus, it is important that the anesthetist choose suitable accessories to reduce dead space. The Dräger anesthetic devices Cicero EM, Cato, PhysioFlex and Julian are marked by a significant lack of apparatus dead space volume. The pediatric Y-piece has both optimal form and size, and includes a connection for capnography sample lines so that other adapters with additional dead space need not be used.

5.5 Anesthetic Machines

5.5.1 Cicero EM/Cato

The anesthetic workstations Cicero EM and Cato are equipped with an electrically driven piston respirator and a fresh-gas decoupler, as well as a very tight breathing system which supports both low-flow or minimal flow anesthesia. The tightness of the breathing system is determined during an automatic power-on self test. The respirator in these devices can be operated in the following modes: manual/spontaneous, IPPV, SIMV, and PCV. It also supports precision ventilation for even the lowest tidal volumes (up to 10 ml in IPPV) and at high respiratory rates (up to 80/min). The machines have standard features including the previously mentioned dynamic compliance correction which automatically and continuously adjusts itself to the chosen system configuration [Feldman, 1999].

The smallest tidal volumes can be reached with PCV where leakage is also compensated for. The respirator provides optimal breathing gas pre-warming through a heating element in the breathing system. If heatable hoses are used, the condition of the breathing gas can be improved even more (see Chapter 5.8).

The difference between the Cicero EM and Cato devices is both in monitoring equipment and in the dimensions of integration. Cicero EM offers a large portion of integration. By integrating monitoring for breathing gas and hemodynamics, the pediatric patient can be monitored in the best way possible –especially if the appropriate limits are set according to each individual case. In order to simplify the extensiveness of these settings, the Cicero EM system screen allows the user, one time only, to change the configuration of a specific set of limits.



Cato

How low is the minimum tidal volume which an anesthetic machine can apply?



Cicero EM

This screen is activated each time the neonatal mode is chosen. In the neonatal mode, measured value ranges for the volumeter can be adjusted and the rate of change of the curves displayed for hemodynamic measured values can be set. In addition to these, pediatric alarm limits for NiBP, HR, pulse, minute volume and special pressure algorithms can also be activated.

The hemodynamic parameters ECG, NiBP, iBP, temperature and SpO₂ have been integrated into the mobile parameter box of the anesthetic workstation Cicero EM. The parameter box eliminates the annoying connecting and disconnecting of sensors before and after transferring the patient, because the parameter box is brought to the operating theater with the pediatric patient and placed, quite easily, in its holder. Other characteristics of these anesthetic machines are compiled in Table 22.

Figure 26: Functional schematics of the anesthetic workstation Cicero EM (insp.: inspiration, exp.: expiration)

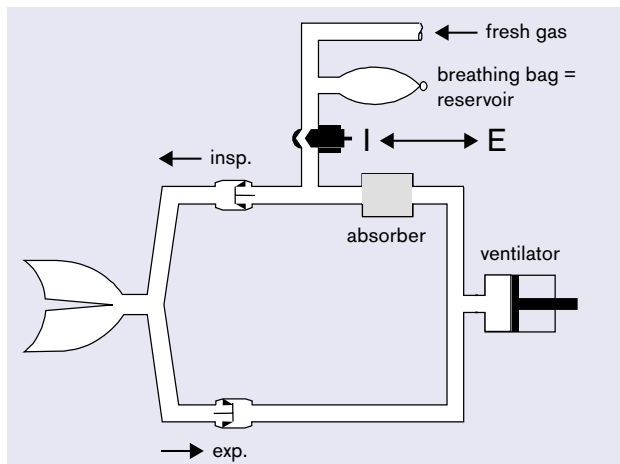

5.5.2 Julian

The anesthetic workstation Julian has been ergonomically optimized and comes equipped with an electronically controlled, pneumatically driven membrane and a heatable breathing system. This system was developed to be a rebreathing system, optimized for low-flow anesthesia and able to be operated in the minimal flow range. A high level of system tightness and electronic fresh-gas delivery make it possible to make precision settings for very small flows and to change quickly between high and low flows. Gas delivery is not controlled by mechanical flowmeters but rather by an electronically controlled mixer for which the anesthetist only has to set the oxygen and carrier gas concentrations and the fresh-gas flow.

In order to prevent the amount of volume delivered in IPPV from changing when the fresh-gas flow is changed and thus to keep the amount of CO₂ exhaled by the patient constant, the respirator in Julian has a fresh-gas decoupler just like the respirators of Cicero EM and Cato. Here too, dynamic compliance compensation is carried out parallel to changing patient compliance. The respirator can be operated in three different modes: manual/spontaneous, IPPV and PCV.



Julian



PhysioFlex

5.5.3 PhysioFlex

PhysioFlex is the only anesthetic machine which allows quantitative inhalation anesthesia to be carried out in a closed system; that means the gas uptake of the patient, eventual losses due to leakage and the amount of gas delivered are all balanced. The heart of this anesthetic machine, the ventilator, is a system designed with membrane chambers with a volumetric capacity of 625 ml each, connected in parallel. According to the selected tidal volume, one or more membrane chambers are in use parallel to the breathing circuit. These chambers are the pneumatic drive for the respirator and the manual ventilation circuit including the hand bag which is separated from the completely closed breathing circuit. A blower, built into the breathing circuit, produces a high flow of 70 l/min in the system. This causes the circulating anesthetic gas to flow in one direction only (without return flow), while enabling rapid gas mixing and CO₂ elimination. CO₂ is eliminated by a CO₂ absorber, integrated in the circle system.

The closed system has three electronic feedback control circuits integrated with each other for O₂ concentration, volatile anesthetic agents concentration and system volume (carrier gas). The O₂ concentration is kept constant within the O₂ control circuit by continuous paramagnetic measurements. If the oxygen concentration decreases as a result of patient uptake, oxygen will be added to the system until the measured oxygen value reaches the set value. In addition to this, end-tidal agent concentration is determined by an infrared measuring bench and maintained by injecting liquid volatile agent. In order to reduce or completely flush out anesthetic agent, the system is equipped with a charcoal filter.

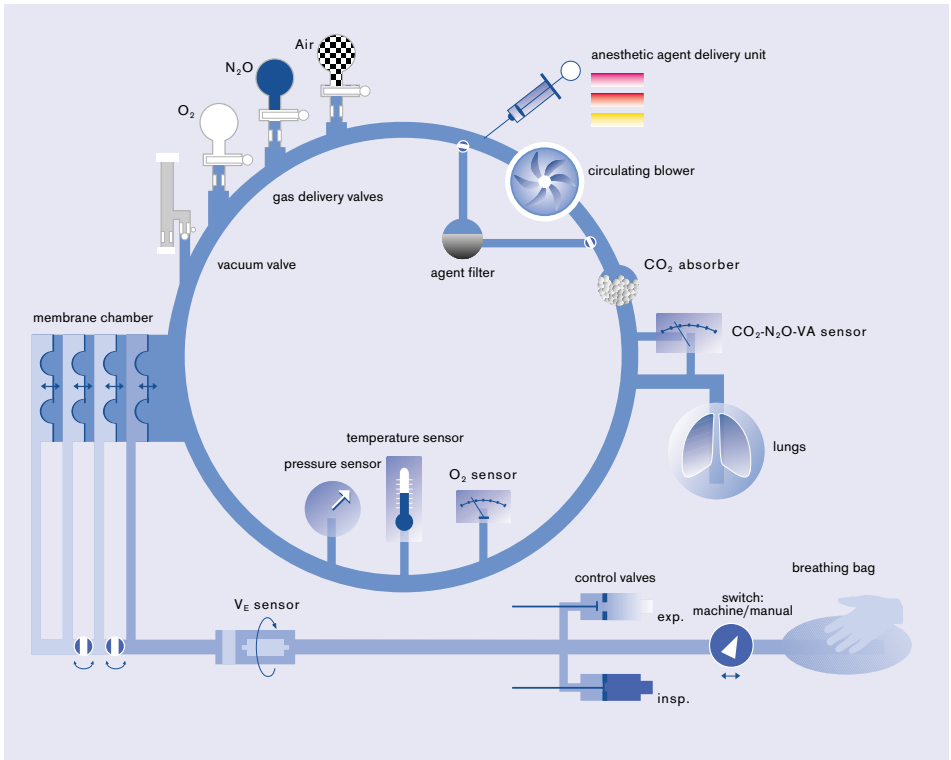

Figure 27: Functional schematics of the closed system PhysioFlex

Carrier gas is controlled within the system's volume control circuit, and the membrane's position right after the patient's inspiratory phase is used as a reference point for control. The patient's carrier gas uptake does not return the chamber to its original position by the end of expiration, so carrier gas is added to the system until that original position is attained. The amount of carrier gas delivered then equals patient uptake since oxygen and volatile agent are added in small doses within this concentration. In addition, this control system can compensate for leakage of up to 15 l/min which come from e.g. using unblocked tubes.

The end-expiratory control circuit for volatile anesthetic agents is carried out in a closed system for those pediatric patients being ventilated through intubation or laryngeal masks. When mask ventilation is being carried out, the inspiratory control circuit is operated using an increased fresh-gas flow of at least 600 ml/min because end-tidal volume measurements are not available.

What are the advantages of closed-system ventilation for pediatric anesthesia?

Due to physiological factors, children build up an autogenic PEEP in the larynx area during expiration. This develops along the closed vocal chords as a result of expiration itself and a narrow nasal passage. In order to maintain physiological control over the expiratory phase, PhysioFlex was equipped with the so-called ALICE system which simulates the function of the vocal chords (ALICE = automatic lung inflation control effect). Autogenic PEEP (or intrinsic PEEP) helps avoid end-expiratory alveolar collapse during expiration in IPPV or PCV which is caused by the high closing volume of pediatric patients. It also helps preserve functional residual capacity (optimizing the surface available for gas exchange).

The ALICE system, which automatically adapts the whole system to changes in lung compliance, is run by flow parameters, not ventilation parameters. In this scheme, control valves adapt the flow to changes in dynamic lung compliance which is determined every three respiratory strokes, continuously. The ALICE system allows an ideal flow curve to be automatically generated; this curve does not have to be set by the user. Figure 28 shows a theoretical pressure curve (P) and a subdued physiological pressure curve (Pp) e.g. in PCV.

This device also provides additional important information on metabolism by registering oxygen uptake and thus, provides an early warning system for e.g. the start of malignant hyperthermia, changes in the depth of anesthesia, bronchospasm and stress.

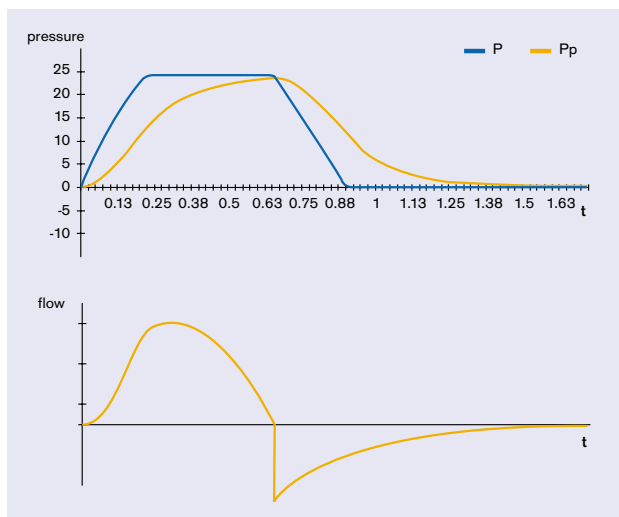

Figure 28: The ALICE system in the anesthetic machine PhysioFlex

	Julian	Cicero EM/Cato	PhysioFlex
mechanical ventilation modes	IPPV, PCV	IPPV, SIMV, PCV	IPPV, PCV
breathing system	partial rebreathing	partial rebreathing	complete rebreathing
respirator principle	electronically time-cycled, pneumatically driven membrane	electronically time-cycled, electronically drive piston-cylinder unit	electronically time-cycled, pneumatically driven 4 membrane chambers
fresh-gas decoupler	yes	yes	(yes)
leak compensation	yes*	yes*	yes (up to 20 l/min)
compliance compensation	yes, as of Software 2.0**	yes	yes
compliance with full absorber, without breathing hoses	approx. 4.5 ml/mbar	4 ml/mbar	approx. 2.3 to 3.8***
leak	< 150 ml at 30 mbar	< 120 ml at 30 mbar	25 ml bei 10 mbar
hemodynamic monitoring	no	yes****	no
metabolic monitoring	no	no	yes
tidal volume (V_T)	IPPV 50 to 1400 ml PCV 20 to 1400 ml	10 to 1400 ml 10 to 1400 ml	40 to 2000 ml 15 to 2000 ml
pressure limit (Pmax) for IPPV	10 to 70 mbar	10 to 70 mbar	15 to 65 mbar
pressure limit for PCV	(PEEP +1) to 70 mbar	10 to 80 mbar	6 to 60 mbar
I:E ratio	1: 4 to 2:1	1:3 to 2:1	1:4 to 4:1
respiratory rate (IPPV, PCV)	6 to 60/min	6 to 80/min	6 to 80/min
respiratory rate (SIMV)		3 to 80/min	
PEEP	0 to 20 mbar	0 to 20 mbar	0 to 20 mbar
inspiratory flow (IPPV)	3 to 75 l/min	5 to 75 l/min	9 to 90 l/min
inspiratory flow (PCV)	5 to 50 l/min	5 to 75 l/min	autoflow

Table 22: Characteristics of individual anesthetic workstations

* Only in PCV.

** Upgrade Software 2.n: what was up to this point static compliance compensation was replaced with dynamic compensation.

*** Depending on the number of membrane chambers.

**** With Cato: only in connection with patient monitor PM8040 or PM8060 Vitara.



*Children, like all patients,
require careful,
considerate monitoring.*

5.6 Monitoring

The anesthetist receives information about the patient's state of health by monitoring skin color and respiration. With the aid of the stethoscope, the anesthetist can observe thorax movement and auscultation of the lungs (tube dislocation). In addition to this, device-specific information is of great importance. All breathing gas monitoring is integrated into the anesthetic workstation and includes airway pressure, minute volume, breathing gas temperature, O₂, CO₂ and N₂O concentrations, as well as the concentrations of each of the anesthetic agents. Hemodynamic monitoring, the extent of which varies in the anesthetic workstations Cicero EM, Cato, Julian and PhysioFlex (see Table 24), is important for pediatric monitoring. In contrast to adults, children have high heart rates, low systolic discharge and low blood pressure. A decrease in the heart rate of a pediatric patient is, for instance, often a sign of hypoxia; this can also be interpolated from a decrease in functional oxygen saturation, SpO₂.

The following are used for monitoring purposes:

What kind of monitoring is used for pediatric anesthesia and what special features are available for this age group?

- stethoscope
- pulse oximetry
- body temperature
- blood pressure (NiBP, iBP)
- ECG
- capnography
- pressure measurements
- volumetry
- anesthetic agent concentration
- inspiratory oxygen concentration

The closed-system anesthetic workstation PhysioFlex has been extended to include a special feature for monitoring the metabolic rate of pediatric patients by using the parameters:

- oxygen/N₂O uptake
- anesthetic agent uptake

Other clinical monitoring, depending on the operation, includes urine sampling, blood-gas analyses and acid-base parameters, or other hemodynamic monitoring like relaxometry and EEG.

5.6.1 The Stethoscope

At present, the stethoscope is used in every case of pediatric anesthesia. It can be placed at either a precordial position (above the top left side of the thorax) or an esophageal position, and is used to monitor cardiac rhythm and breathing. Accidental stomach inflation and air embolisms can also be determined with the stethoscope. The loudness and tone of the heartbeats provide information on the fullness and contractional force of the heart.

5.6.2 Pulse Oximetry

This non-invasive standard process is used to continuously measure the arterial oxygen saturation level of each pediatric patient undergoing anesthesia, even neonates. Hypoxia, which occurs during anesthesia rather frequently in pediatric patients of less than two years, can be detected early with the help of pulse oximetry, making the early detection of acute oxygenation disorders also possible [Cote, 1991]. In most intra-operative cases, pulse oximetry has replaced transcutaneous oxygen measurements because the exactness of measurement of the transcutaneous method is influenced by such factors as blood circulation in the skin, hypothermia, and hypovolemia. Hyperoxia is the exception to this since it cannot be detected with pulse oximetry.

In some cases, the oxygen saturation level of the hemoglobin measured with pulse oximetry and the oxygen partial pressure (p_aO_2) from the blood gas analysis do not concur exactly. There are many factors which affect oxygen's affinity for hemoglobin and thus cause a shift in the oxygen-binding curve to the right or left (see Figure 29). A curve shifted to the left represents a high level of oxygen affinity, as is the case in hypothermia and alkalosis, and when a high level of fetal hemoglobin is present. A curve shifted to the right, meaning that oxygen delivery is facilitated, is caused, for instance, by acidosis or an increase in concentration of 2,3 diphosphoglycerate (DPG).

To avoid a p_aO_2 of > 70 mmHg and thus, the risk of retinopathy of prematurity, the oxygen saturation level of premature infants and neonates should not exceed 90 to 95 % (see Figure 30 and Chapter 2.1.7, Extrapulmonary Oxygen Toxicity).

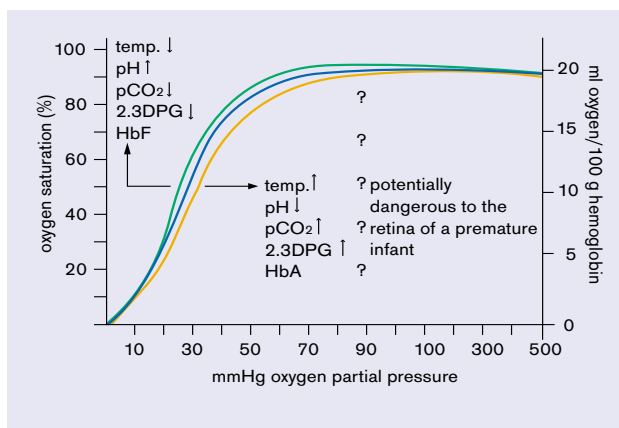
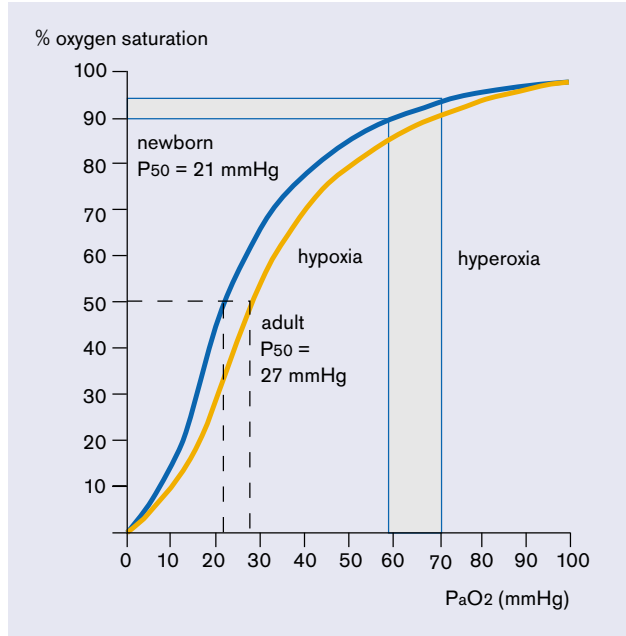

Figure 29: Oxygen-binding curve [Nunn, 1987]
 The curve shifted to the left represents a high level of oxygen affinity, as is the case with low temperatures, high pH levels, low $p_a\text{CO}_2$ levels, lowered 2.3 DPG levels, or HbF. A curve shifted to the right is, for instance, caused by high temperatures, low pH levels, high $p_a\text{CO}_2$ levels, high 2.3 DPG levels, or HbA.

To carry out pulse oximetry, a sensor is clipped onto a finger or an earlobe. The sensor clip must be well attached without being too tight; if the clip sits too tight, the flow of blood through the tissue is disrupted. Dräger recommends the Nellcor sensor, Oxisensor I-20 for pediatric patients weighing up to 20 kg and Oxisensor D-20 for pediatric patients weighing between 10 and 50 kg. The sensor contains two light-emitting diodes which alternately send out infrared rays with wave lengths of between 660 and 920 nm to determine the level of oxygenated hemoglobin. A photo detector on the opposite side measures the intensity of the rays.

For those premature infants and newborns having an open ductus arteriosus, the sensor should be affixed to the right hand of the right arm, or to the earlobe. If the sensor were to be clipped to the left side of the patient, the oxygen saturation measurements would be incorrect because the blood on the left side is not sufficiently oxygenized.

Figure 30: An oxygen-binding curve comparing newborns to adults [Nunn, 1987] Fetal hemoglobin has a higher level of oxygen affinity than adult hemoglobin does, which means that the O_2 dissociation curve of newborns shifts to the left [Nunn, 1987]. That part of the chart highlighted in beige shows the level of oxygenation targeted in order to avoid hyperoxia without, on the other hand, allowing hypoxia to occur.



Potential sources of error in pulse oximetry include the presence of bright sources of light, movement, electrical cauterization and carbon monoxide poisoning. The blood pressure cuff could also cause arterial pulsation to be intermittent which could, in turn, set off device alarms.

5.6.3 Measuring Body Temperature

Children, whose body surface is relatively large, absorb and give off heat more quickly than adults. Newborns, infants and small children are at risk of hypothermia during the perioperative phase because most anesthetic agents suppress the reflexes which, in children, are responsible for maintaining body temperature. Additional warmth can also be lost if the breathing gas to be inspired is not optimally warmed and humidified (see Chapter 5.8, Breathing Gas Conditioning). To protect pediatric patients, measures must be taken to preserve heat and thus maintain body temperature during anesthesia (see page 34).

The targeted temperature for a pediatric patient is between 36 and 37.5 °C. Caution is called for if the patient's temperature falls below 35.5 °C. Infants often react to abnormally low temperatures with postoperative respiratory depression. Oxygen consumption increases as the result of an increase in the metabolic rate which, again, can cause serious problems because an increase in the pediatric patient's cardiac output is limited. Because of the risk of hypoventilation occurring in hypothermic pediatric patients, children are ventilated from the end of the operation until their body temperature has returned to normal. At the time of extubation, the pediatric patient's body temperature should not be below 36 °C.

The body temperature of a pediatric patient should be monitored at least during those operations expected to last longer than 30 minutes. Premature newborns and neonates undergoing surgery should have their temperatures monitored regardless of the length of the operation.

Body temperature may be taken rectally, nasopharyngeally or esophageally. If the esophageal method is used on pediatric patients, the measurement must be taken in the distal esophagus since the temperature there is less likely to be affected by breathing gases coming from the trachea. The nasopharyngeal probe could cause lesions of the nasal passage's mucus membrane which could lead to postoperative respiratory complications.

In addition to body temperature measuring equipment, three different temperature probes from Dräger make it possible to determine airway temperature and peripheral skin temperatures.

5.6.4 Measuring Blood Pressure (NiBP/iBP)

The non-invasive oscillatory method for measuring blood pressure (NiBP), highly reliable and exact, provides valuable information on the state of the pediatric circulatory system. This information is based on recognizing the fact that changes in blood pressure can be measured by using an inflated cuff which partially closes off the arteries through which the blood must flow. Registering the first oscillation of the arteries determines systolic blood pressure, the maximum number of oscillations determines arterial mean pressure, and the diastolic pressure can be determined from that point at which the oscillations can no longer be made out.

When using the non-invasive blood pressure monitoring method, it is important to have the right size cuff to ensure exactness of measurement and the pediatric patient's well-being. The Dräger monitoring systems are equipped with an adaptable cuff for use on neonates and children. When using the optimal cuff width of 1.2 x the diameter of the upper arm, the care person should make sure the cuff is not too wide because if it is, the values calculated could be too low. Incorrect blood pressure values can also be caused by movement.

The neonatal mode of the Dräger monitoring systems measures the initial and maximum cuff pressures of this age group, calculates the maximum measuring period and displays alarm limits.

Blood pressure must be taken invasively in order for it to be registered continuously and beat-for-beat. Pressure built up in the artery as a result of blood being pumped out of the heart is transferred through an arterial cannule to the membrane of a pressure recorder, changed into an electric signal and, in this form, sent to an amplifier. The invasively recorded blood pressure is then displayed on the screen of the monitoring unit as both a digital reading and a curve.

Invasive blood pressure measurements (iBP) are mainly used in those pediatric operations which will most likely include large fluid transfusions, respiratory disorders or instability of the circulatory system, since hemodynamic disorders can be ascertained more quickly with this method.

The invasive method can be used to take arterial blood pressure, central venous pressure and pulmonary artery pressure.

The arterial blood pressure measuring method is used in pediatric anesthesia for, among other things, neurological or cardiac surgery, for children suffering multiple trauma or who are septic. The arterial blood pressure curve should run biphasic if the patient is stable, otherwise the curve is subdued or compressed (see Figure 31). A subdued line is usually caused by air bubbles or blockage in the system. In this case, the systolic pressure measurement is too low and the diastolic pressure measurement too high. If the probe lines are too long, the curve is compressed [Larsen].

Pulmonary artery pressure measurements are used in pediatric anesthesia for operations on newborns with diaphragmatic hernias, for children with a serious case of sepsis, or for heart disorders associated with pulmonary hypertension. Calculations for the filling pressure of the left atrium are rarely used for infants because of the thickness of the catheter.

This is also true for central venous pressure measurements which serve as a parameter for the total volume of the circulatory system. This kind of measurement is used during operations with high volume turnover and for cardiac surgery.

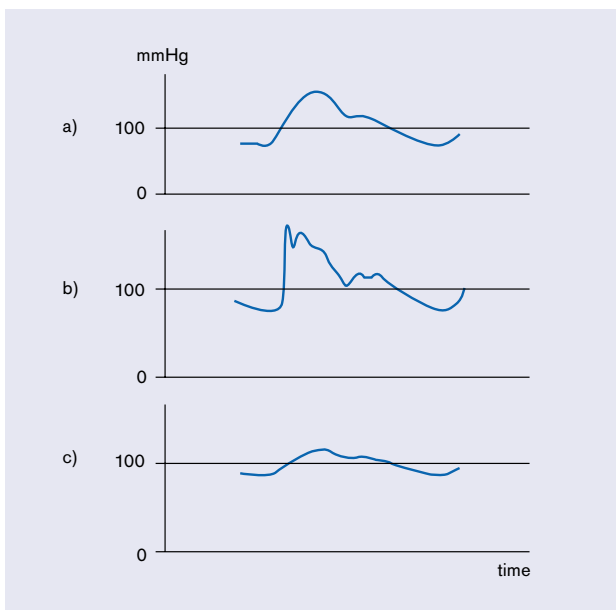

Figure 31: Errors occurring in arterial blood pressure measurements

- a) a normal curve
- b) a compressed curve
- c) a subdued curve

5.6.5 The ECG

Electrocardiography (ECG) allows the electrical potential which precedes every heartbeat to be transferred over the body's electrostatic field to the skin from whence it can be easily picked up by special electrodes. The ECG is one of the standard monitoring methods used in pediatric anesthesia and reliably displays both heart rate and diagnostics for arrhythmia, although serious arrhythmia does not usually occur in children. Causes of arrhythmia are manifold. On the one hand, there are the problems associated with homeostasis like hypercarbia, hypo- and hyperkalemia, or an increased level of catecholamine. On the other hand, hypoxia and hypovolemia can also trigger tachycardia or, in infants and small children, bradycardia.

ECGs also make it possible to determine arrhythmic disorders like supra- and ventricular extrasystoles, AV dissociation, as well as nodal rhythms under halothane anesthesia (see Figure 32). Electrocardiograph monitoring for changes in ST segments are only used sparingly in pediatric anesthesia e.g. for Kawasaki disease, coronary artery surgery and hereditary abnormalities of the arteries [McNiece, 1983].

Figure 32: Halothane-induced extrasystoles [Kretz, 1998]



The ECG of a newborn differs from that of an adult as pertains to the following:

- higher heart rate
- shorter QRS interval
- rapid changing of heart rate
- larger range of variation
- weaker ECG signals
- more artefacts

In addition, a transformation takes place in newborns from physiological right-sided hypertrophy (e.g. 5 days old) to biventricular hypertrophy (3 months old) to physiological left-sided hypertrophy by the time the child is 6 months old (see Figure 33). The neonatal mode on Dräger devices adjusts alarm limits to fit pediatric monitoring criteria, e.g. higher heart rate.













age	5 days	3 months	6 months
V1	 Rs	 Rs	 rS
V2	 Rs	 Rs	 rS
V5	 RS	 Rs	 Rs
V6	 RS	 Rs	 Rs
	physiological right-sided hypertrophy	biventricular hypertrophy	physiological left-sided hypertrophy

Figure 33: Transformation of the physiological right-sided hypertrophy into a left-sided hypertrophy during the first 6 months of a child's life shown in the varying RS relations of the parasternal and left precordial ECG derivations

5.6.6 Capnography

Capnography, an infrared end-expiratory measurement for CO₂ absorption, is a non-invasive, continuous monitoring process which provides important information for controlling pediatric patient ventilation. This monitoring method defines the minute volume required for children being ventilated and helps ensure the correct positioning of the tube during each intubation process (see Figure 35). Air embolisms and respiratory depression cause the end-expiratory pCO₂ value to fall abruptly. In addition, changes in metabolic rate can also be diagnosed. An increase in the end-expiratory pCO₂ value is usually the first sign of malignant hyperthermia. Figure 34 lists other characteristics of malignant hyperthermia.

If CO₂ is measured during the inspiratory phase, either the soda lime needs replacing or there is rebreathing due to a missing or faulty valve plate.

Figure 34: Malignant hyperthermia

Signs of malignant hyperthermia are:

- tachycardia
- tachyarrhythmia
- hypercapnia
- cyanosis
- metabolic acidosis
- hyperthermia
- increase of creatine kinase
- myoglobinemia

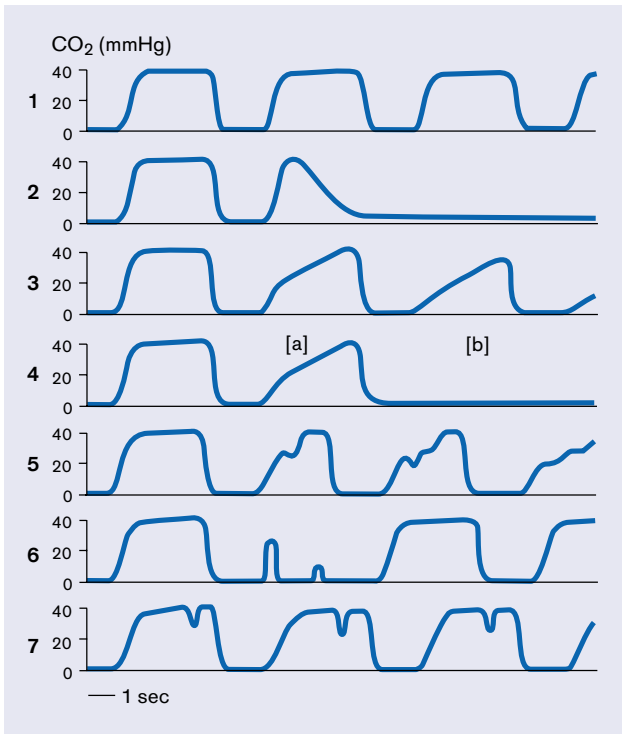

Figure 35: Capnography
 [Kretz, 1998]
 Shown here: a normal capnogram (1), disconnection and apnea (2), obstruction of the airway (3), kinked (a) or totally misplaced (b) tube (4), dislocated tube in right main bronchus (5), dislocated tube in oropharynx (6), patient beginning to breath spontaneously, but still under the influence of relaxants (7)

There are two different measuring methods for capnography: the mainstream or flow-through method, and the side-stream or aspirating method. The so-called mainstream capnography takes a measurement directly from the main respiratory flow, whereas a side-stream capnography removes sample gas from the breathing circuit and analyzes it on the outside. The biggest disadvantage of the mainstream method, which otherwise provides good results without a latent period, is increased dead space. Aside from that, the weight of the sensors –attached close to the tube– is considered troublesome and the sensors themselves can damage the skin with the heat they produce.

Otherwise very handy, some publications point out a disadvantage of side-stream capnography as its having slurred curves the quality of which depends on the length and condition of the sample hose and on the ascension rate of the capnogram. To ensure reliable measurements from the Dräger side-stream capnography, sample gas is taken from between the distal end of the tube and the Y-piece. In order to reduce dead space, the sample gas line has been integrated into the Y-piece; it is not, as used to be the case, a separate T-piece.

There is a scavenger integrated into the breathing system which returns the sample gas to the system so that minute volume is not effected. This is especially good for pediatric patients who would otherwise react poorly to minute volume reductions. If a sample gas scavenger was not connected to the system, the amount of tidal volume delivered to a child's lungs would typically be reduced by 5 to 10 percent.

A suction rate of 200 ml/min should be set for measuring CO₂, especially when treating pediatric patients, in order to register the capnograph signal which changes rapidly at higher respiratory rates. The suction rate affects the rate of increase t_{10-90} ; this is the time it takes the capnograph to display a change in concentration of 10 % to 90 %. This would be about 0.3 seconds at a suction rate of 200 ml/min on the anesthetic workstations Cicero EM and Julian. If the suction rate is 60 ml/min, the capnogram signal would be delayed relative to that, i.e. the rate of increase t_{10-90} would rise from 0.3 sec to 1 sec [Jaklitsch, 1995]. This produces a sine-like CO₂ curve and an iCO₂ which would be too high compared to the capillary CO₂ level (see Figure 36).

For it to be reliable, the capnogram can only be used in partial rebreathing, closed or non-rebreathing systems with non-rebreathing valves. Non-rebreathing systems without non-rebreathing valves (Kuhn, Bain) could cause problems because fresh gas and expiratory gas could mix. In this case, sample gas has to be taken from a place close to the tip of the tube, otherwise the etCO₂ value will be too low.

How much is volume-controlled or, respectively, pressure-controlled ventilation affected by a gas measurement procedure during side-stream capnography?

Figure 36: Rate of increase t_{10-90} for CO_2 measurements

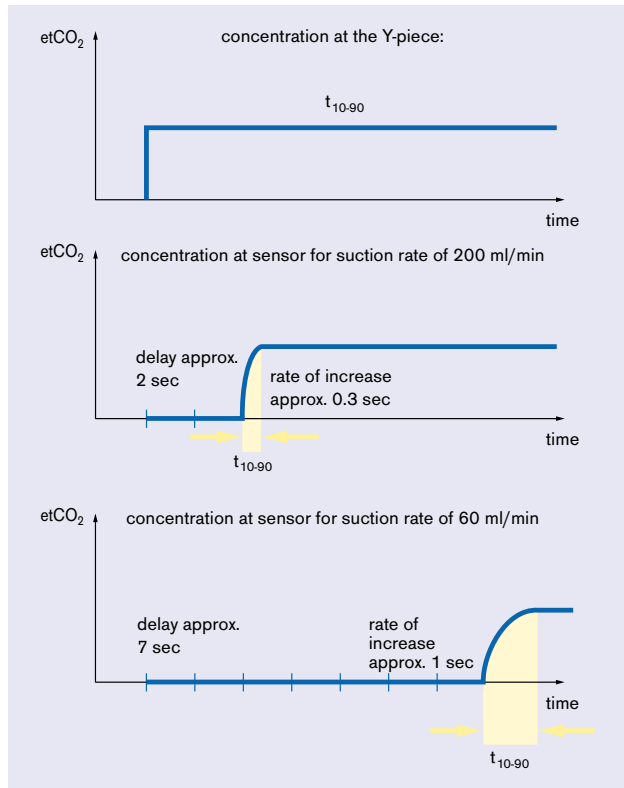

5.6.7 Measuring Respiratory Pressure

Respiratory pressure (P_{AW}) is an important parameter for registering changes in lung compliance, lung resistance, and for registering obstructions and disconnection. A respiratory pressure of up to 20 mbar can be obtained in the lungs of a healthy infant, but if there is an obstruction, this value would be exceeded. If something has become disconnected, it can be recognized by observing that the set lower pressure limit value no longer runs periodically in both directions.

Anesthetic machines from Dräger are equipped with a safety valve to limit pressure and thus protect the patient from barotrauma.

Current non-rebreathing systems are not equipped to measure respiratory pressure so they have to be modified accordingly.

5.6.8 Volumetry

The anesthetic workstations Cicero EM, Cato, Julian and PhysioFlex from Dräger offer a volumeter function which precisely monitors the expiratory volume (V_T) of every breath during spontaneous, manual or volume-controlled ventilation. The function itself adds up the individual tidal volumes over one minute, allowing the spontaneous ventilation used to be judged accordingly.

In contrast to PhysioFlex, which incorporates a capacitive measuring principle for its volumetric measurements, the other anesthetic machines mentioned above use a hot-wire anemometer procedure. In this procedure, a very thin platinum wire is heated to a temperature of about 180 °C using electric current. If gas flows past it, the wire cools. The larger the volume is that flows past per unit of time, the faster the wire cools. If the temperature of the platinum wire is kept constant by using a control loop, the electric current required to maintain this constant can be used as a point of reference for the gas flow. For example, a high flow rate requires a high level of electric current in order to keep the temperature constant. The volume is obtained by electronically integrating the strength of current over a period of time.

This measurement is not affected by gases with different properties (density, viscosity, conductivity) since it is corrected by an internal algorithm. Non-rebreathing systems do not have a practical method of determining expiratory volume (see Table 23, page 130).

5.6.9 Measuring the Concentration of Anesthetic Agent

In order to recognize a under- or overdose of anesthetic agent, the inspiratory agent concentration is measured. Three light wave lengths of the infrared zone are employed to register the volume concentrations of the five volatile anesthetic agents available. Anesthetic agent is identified and its concentration calculated from the strength of absorption of these three wave lengths.

The Dräger anesthetic workstations Cicero EM, Cato and Julian, and as of 2000 PhysioFlex too, are equipped with an automatic anesthetic agent detector. A change in anesthetic agent, which often takes place during pediatric anesthesia between the induction phase and the phase of maintaining depth of anesthesia, causes the agent to be in a mixed state for a short period of time. This mixed state is registered by the anesthetic workstations Cicero EM, Cato, PhysioFlex* and Julian** and its primary component is identified and quantified. In such cases, the accuracy of the measurement can be limited.

The anesthetic workstation Julian** also allows anesthetic agent to be automatically set and delivered according to age-related MAC values.

* As of 2000.

** With software version 3.0.

5.6.10 Measuring the Inspiratory Oxygen Concentration

Using an oxygen probe based on principles of galvanic or, as is the case for PhysioFlex, paramagnetic cells, the inspiratory oxygen concentration can be easily determined in partial rebreathing and closed systems.

Oxygen is measured in the fresh-gas flow of non-rebreathing systems. In such systems, if the fresh-gas flow is too low, partial rebreathing could result, causing the oxygen portion of the inspiratory gas mixture to be lower than that of the fresh-gas phase.

Both inspiratory and expiratory oxygen concentrations are displayed on the screen of the anesthetic workstations Cicero EM, Cato, PhysioFlex and Julian.

5.6.11 Oxygen Uptake

When the anesthetic workstations Cicero EM, Cato and/or Julian are used, the anesthetist manually determines the amount of breathing gas and anesthetic agent in the fresh gas (carrier gas) using preset values. In comparison, the closed system PhysioFlex controls breathing gases and anesthetic agent on its own, depending on the patient uptake, which changes continuously.

With a paramagnetic oxygen analyzer, the oxygen concentration within the breathing circuit is continually measured. The device compares the measured value with the set value for oxygen concentration. If the measured value is lower, PhysioFlex uses an oxygen valve to measure and deliver the amount of oxygen needed to reach the set value.

5.6.12 Anesthetic Agent Uptake

Anesthetic agent uptake monitoring is another function contained in PhysioFlex in which the anesthetic agent concentration is continually measured using an infrared analyzer. The device compares the measured value to the set end-expiratory value or respectively, to the desired inspiratory value. If the concentration is too low, the device delivers volatile agent to the respiratory system in liquid form. If the concentration is too high, the respiratory system is bypassed and the charcoal filter is used until the desired value has been reached again.

Table 23: Possible ventilation monitoring for rebreathing and non-rebreathing systems [Fösel, 1984]

	flow-controlled non-rebreathing-system (Kuhn, Bain, Jackson-Rees)	valve-controlled non-rebreathing-system (Paedi-System)	rebreathing system
precordial stethoscope	yes	yes	yes
inspiratory O ₂ concentration	with additional equipment only for fresh gas	yes	yes
respiratory pressure	with additional equipment	yes	yes
expiratory volume	no	yes	yes
capnography	no	yes	yes

	Julian	Cicero EM/Cato	PhysioFlex
pulse oximetry	optional	yes	optional*
temperature	optional	yes	optional
NiBP	optional	yes	optional
ECG	optional	yes	optional
capnography	Y-piece	Y-piece	Y-piece
respiratory pressure measuring	yes	yes	yes
volumetry	yes	yes	yes
agent measuring	automatic, all 5 gases	automatic, all 5 gases	automatic, all 5 gases**
oxygen concentration measuring	inspiratory and expiratory	inspiratory and expiratory	inspiratory and expiratory
oxygen uptake	no	no	yes
agent uptake	no	no	yes

Table 24: Monitoring for the anesthetic workstation

* When connected to a patient monitor.

** As of 2000.

Can low-flow anesthesia be carried out for pediatric anesthesia?

5.7 Low-flow Anesthesia

For years now several publications have provided information on low-flow techniques for pediatric anesthesia in which the fresh-gas flow is reduced to < 20 % of the minute volume. Children provide ideal anatomical conditions for carrying out anesthesia with reduced fresh-gas flows. The respiratory system of a pediatric patient equilibrates more quickly with anesthetic gases due to the slightness of the patient's weight which has lower oxygen consumption, absorbs less nitrous oxide and retains less dissolved nitrogen within the body itself, and due to the fact that the anesthetic agent has little room for distribution [Weiser, 1993].

Pediatric anesthesia using a fresh-gas flow of 1 l/min and 0.5 l/min corresponds to the definition of adult low-flow or, respectively, minimal flow anesthesia. Since these two terms refer to the fresh-gas flow and the level of rebreathing associated with a particular level, a minimal flow situation is not present even when the fresh-gas input is 0.5 l/min for an infant of e.g. 5 kg. This fresh-gas flow still replaces half of the infant's minute volume.

The advantages of low-flow adult anesthesia are simultaneously the advantages of low-flow pediatric anesthesia, like reduced environmental stress due to anesthetic agent vapors, reduced costs, and improved breathing gas condition.

Nevertheless, there are still hardly any studies available on low-flow pediatric anesthesia with flow rates lower than 1 l/min.

This might be due to historical, traditional reservations which exist and claim that low-flow anesthesia for small children can only be carried out using flow-controlled rebreathing systems, or that the performance features of an adult respirator cannot satisfy the demands of pediatric anesthesia [Wieser, 1993]. In order to ensure that low-flow anesthesia is safe for pediatric anesthesia, demands on the anesthetic machines involved, like system tightness and precision, have been increased considerably.

The modern anesthetic workstations from Dräger: Julian, Cato, Cicero EM and PhysioFlex, equipped with pediatric circle systems, exceed these demands. The already high degree of system tightness is checked using self test sequences automatically carried out. If leakage occurs, the anesthetist receives a message on the display screen, or it is compensated for in the conventional partial rebreathing systems in PCV or, in the closed system PhysioFlex, in IPPV also. The compliance compensation function included in all four anesthetic workstations allows hose compliance to be compensated for provides precision tidal volume settings of 10, 40 or 50 ml in IPPV.

Extensive monitoring for anesthetic agent, inspiratory oxygen concentration, minute volume, oxygen saturation, CO₂ and pressure is another important component required for carrying out low-flow anesthesia. The fresh-gas decoupling function lets the anesthetist reduce the fresh-gas flow to operate in the low-flow or minimal flow mode without having to worry about the effect of the fresh-gas flow on the applied tidal volume [Baum, 1998].

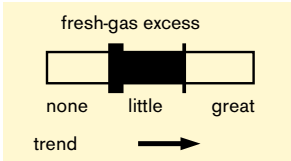

Figure 37: Econometer

The econometer, an integrated part of the anesthetic workstation Cicero EM, provides the anesthetist with additional support for judging the balance of fresh gas (see Figure 37). The fill level of the system is monitored and excess fresh gas is displayed on the screen as a bar diagram. This display provides a basis which the anesthetist can use to reduce the fresh-gas flow to the necessary amount, thus increasing the efficiency of modern anesthetic concepts.

The latest studies from e.g. Peters, Gebhardt and Igarashi point out that low-flow anesthesia can be safely carried out for pediatric anesthesia [Peters, 1998; Gebhardt, 1999; Igarashi, 1998]. Peters comments on the fact that hypoxia and significant CO₂ rebreathing could not be proven to occur during anesthesia procedures for which the Dräger anesthetic workstations Cicero EM and Cato were used on children weighing between 2 and 6 kg (at a flow of 0.6 l/min). To reduce the risk of a decrease in FiO₂, the oxygen consumption of the child was added to the initial fresh-gas composition calculation.

Mask anesthesia with low fresh-gas flows is usually performed only by those anesthetists acquainted with the procedure. Low-flow anesthesia with laryngeal masks for airway protection can be carried out without causing problems. The tightness of a correctly positioned laryngeal mask allows for controlled ventilation in many cases [Möllhoff]. Even the use of an endotracheal tube without a cuff does not exclude the possibility of well-adapted flow reduction if the size of the tube is correctly chosen, particularly since the total gas uptake of an infant or a small child is very low and thus, the level of excess gas comparatively high [Baum, 1998].

Using the closed system PhysioFlex, Fröhlich examined the efficiency of laryngeal masks and uncuffed tubes during low-flow anesthesia. He discovered that both systems were tight enough to carry out low-flow or closed anesthesia. Leakage of only 100 ml/min^{-1} was measured in over 80 % of both systems and this was compensated for by the anesthetic workstation itself, PhysioFlex [Fröhlich, 1997].

In rebreathing systems, an improvement of anesthetic agent condition goes along with a reduction of the fresh-gas flow (see Chapter 5.8, Breathing Gas Conditioning). An absolute humidity for inspiratory gas of between 17 and 30 $\text{mg H}_2\text{O/l}$ and a breathing gas temperature of 28 to 32 °C is the targeted condition for anesthetic ventilation. Kleemann was able to prove in studies on adults that the breathing gas temperature rises to approximately 28 °C after 30 minutes and even to 31.5 °C after 90 minutes at a fresh-gas flow of 0.6 l/min [Kleemann, 1989]. When high-flow anesthesia (6 l/min) is carried out over the same periods, temperatures of only about 23 °C were attained (see Figure 38). In non-rebreathing systems equipped with artificial noses (HME filters), these high temperatures were not able to be reached because of the high fresh-gas flow. Low fresh-gas flows also have a positive influence on breathing gas humidity. In a clinical evaluation of low-flow anesthesia using sevoflurane and the anesthetic workstation Cicero EM, Igarashi proved that the humidity of inspiratory breathing gas significantly rises from 5.6 to 22.8 g m^{-3} during pediatric anesthesia with a fresh-gas flow of 0.6 l/min in contrast to high-flow anesthesia (6 l/min) [Igarashi, 1998].

Figure 38: Interdependence of breathing gas temperatures and fresh-gas flow [Baum, 1998]

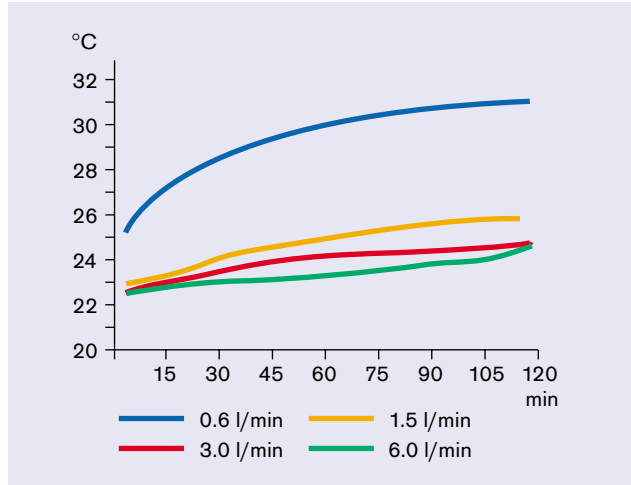

5.7.1 The Wash-in/Wash-out Rate of Anesthetic Agent

The principles of carrying out low-flow pediatric anesthesia as pertains to induction, maintaining depth of anesthesia and the recovery phase do not differ from those of adult anesthesia.

How quickly does the system react to changes in concentration (wash-in/wash-out rate)?

It is extremely important to consider time constants when controlling inhalation anesthesia, especially low-flow anesthesia. What exactly is meant by the term "time constant"? The time constant of an anesthetic machine describes the time it takes a change in fresh-gas concentration to initiate a change in inspiratory concentrations in the anesthetic machine. This constant depends on device volume, pulmonary volume, the amount of gas delivered with the fresh-gas flow, and individual consumption of this gas.

$$\text{time constant: } \frac{\text{device volume} + \text{pulmonary volume}}{\text{fresh-gas flow} - \text{patient uptake}}$$

When the fresh-gas flow is reduced in a partial rebreathing system, the sluggishness of the system increases considerably; this can be best shown by comparing high-flow and minimal flow anesthesia (0.5 l/min) (see Figure 39). During low-flow or minimal flow anesthesia, drastic changes in the fresh-gas concentration can also lead to delays in the course of changes in inspiratory and expiratory anesthetic agent concentrations within the anesthetic system.

A short time constant leads to rapid changes in anesthetic agent concentrations within the system. The time constant can only be shortened by changing the amount of agent vapor delivered to the breathing system with the fresh gas. With conventional anesthetic agents like halothane, isoflurane, and enflurane, this can only be improved by increasing the fresh-gas flow. The newer anesthetic agents desflurane and sevoflurane have low uptakes due only to their specific pharmacodynamic and pharmacokinetic characteristics. If maximum concentrations are used, the time constant can also be decreased for low fresh-gas flows [Baum, 1998].

When considering the above, it should not be forgotten that the course of wash-in and wash-out processes for anesthetic agents differs greatly between partial rebreathing systems and complete rebreathing systems (closed systems). The closed system of the anesthetic workstation PhysioFlex does not require high fresh-gas flows to wash gases into the system. Independently controlled doses of oxygen, carrier gas and anesthetic agent, as well as rapid mixing within the circuit due to a blower, produce a very small time constant and a closed circuit shortly after induction. After the volatile gases have been injected into the system, a child's end-tidal volume concentration can be reached within 4 minutes, regardless of the fresh-gas flow (see Figure 40). Removing or reducing the anesthetic gas concentration also takes place without a high flow phase. The low fresh-gas flow remains unchanged and the anesthetic gases are quickly eliminated by the charcoal filter found in the bypass. The desired value for anesthetic agent concentration is reached within one minute of changing the set value.

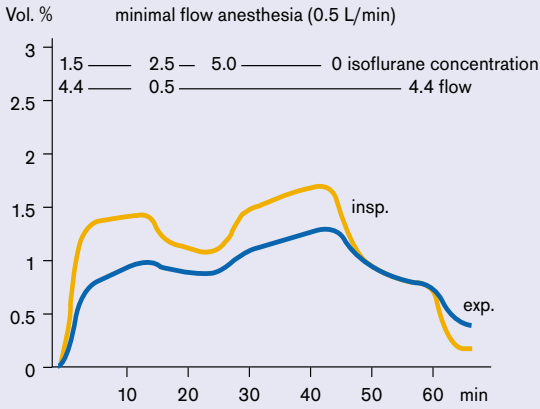
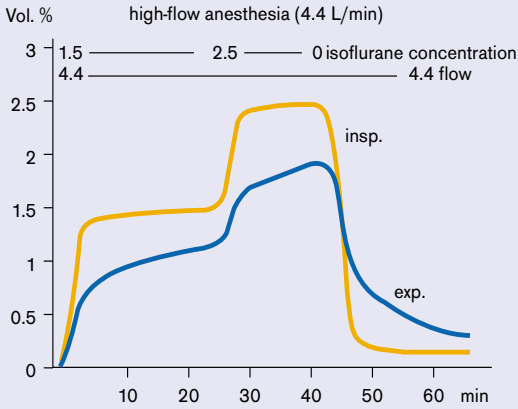
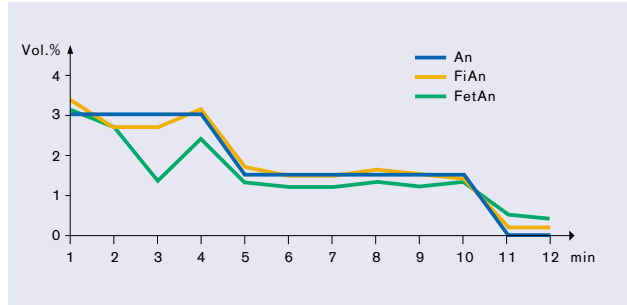

Figure 39: Comparing time constants: high-flow versus minimal flow anesthesia

- inspiratory and expiratory concentrations of isoflurane in the course of high-flow anesthesia (4.4 l/min)
- inspiratory and expiratory concentrations of isoflurane in the course of minimal flow anesthesia (0.5 l/min)

[Baum, 1998]

Figure 40: Controlling anesthesia with PhysioFlex
A two-year old child is inducted with the anesthetic agent halothane, which is then washed out (inspiratory control loop).
An: Vaporizer settings for anesthetic agent; FiAn: inspiratory concentration of anesthetic agent; FetAn: expiratory concentration of anesthetic agent





Children require an optimal environment, adapted to meet their special needs.

5.8 Breathing Gas Conditioning for Anesthetic Ventilation Systems

During natural respiration, the air breathed is warmed and moistened on its way through the nose, throat and windpipe. About three-fourths of this warmth and moisture is provided by the mucus membrane of the nose and throat, the remaining fourth comes from the windpipe. The upper airway also serves as an initial air filter, removing particles from the inspired air by way of nasal hair. If, despite this filtering, foreign debris finds its way to the respiratory tract, mucus encircles it, transports it toward the larynx via cilia and expels it by sneezing.

Endotracheal intubation bypasses the upper airway and its warming/moistening function (see Figure 41). If measures are not taken to compensate for this lost warmth and moisture, the lower airway could dry out [BGM].

This could lead to the following:

- secretion thickening
- reduced cilia movement
- mucus blocking lower airway and tube
- atelectasis build-up from secretion blockage in bronchia, lung infections
- necrosis build-up in respiratory organs

Ventilating with cold and dry air or gases can lead to irritation of the mucus membrane, respiratory epithelium, and even bronchospasm. During anesthetic ventilation, breathing gases should be warmed to between 28 and 32 °C, but not to above 41 °C as this would damage the mucus membrane of the trachea. According to Rathgeber, optimal temperatures are those between 30 and 37 °C with a humidity of 30 to 35 mg H₂O/l [Rathgeber, 1995].

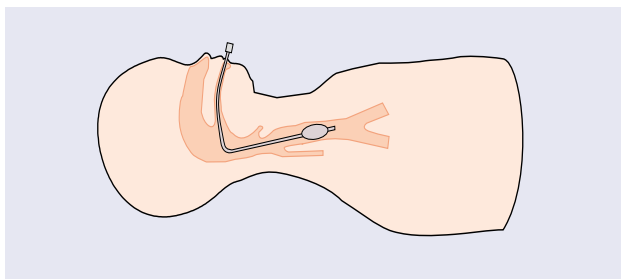

Figure 41: Bypassing the upper airway by way of an endotracheal tube

The loss of warmth and moisture is a serious problem during pediatric anesthesia. The loss of respiratory fluids is significantly larger in children than in adults. Due to the respiratory tract's smaller size, stenosis develops more rapidly in children if dry gases are used for ventilation. Lower CO₂ expiratory levels produce less humidity with the soda lime absorber in the neutralization process. Pediatric patients need vast amounts of energy to warm and humidify dry gases. In order to achieve this, an infant weighing 3 kg uses 10 to 20 % of the total energy available to it.

Why is it necessary to condition breathing gases for children?

Which type of breathing gas humidification should be used, for which age group?

Often, the only way to prevent hypothermia in pediatric patients, whose compensation mechanism for temperature regulation is immature, is to actively warm and humidify the breathing gases (see Table 25, Advantages and disadvantages of various humidifiers). If the operation being performed is of a short duration (up to one hour) and has a low fresh-gas flow (10 % of minute volume), a relative humidity of 60 % can be achieved with partial rebreathing systems not having an active moistening feature. If the operation is longer, active humidification is definitely an advantage. This is why the anesthetic workstations Cicero EM, Cato and Julian have integrated breathing gas warmers and offer optional connections for artificial noses, heatable hoses, or active breathing gas humidifiers. In addition, anesthetic gases are conditioned by the fresh-gas flow (see page 135), and the amount of rebreathing is calculated.

The breathing gas humidifier works according to the principles of an atomizer or nebulizer. Atomizers produce an aerosol by atomizing. In a nebulizer, breathing gas flows through a humidifier chamber and is added to water steam. When it leaves the humidifier, the breathing gas is warmer than the desired tube temperature, but it cools as it passes through the hose system, which means the water condenses. Heatable hose systems counteract this and avoid both a loss of warmth and condensation.

Dräger anesthetic workstations are compatible with the active humidifiers from the company Fischer & Paykel. The active humidifier 720 is used within a tidal volume range of 10 to 200 ml for pediatric anesthesia (see Figure 42). It can also produce humidity of 40 mg/l with saturated steam at 37 °C. This allows the tube to have a relative humidity of > 90 % and the breathing gas to reach a temperature of 31 °C within 10 minutes [Strauß, 1992]. Breathing gas temperatures can be monitored using the Cicero EM anesthetic workstation with the help of a temperature sensor mounted on the Y-piece. To prevent thermal injuries to the respiratory tract, the humidifier is equipped with alarms for overheating, low temperatures and disconnection. While the humidifier is being added to the workstation, increases in compression volume within the circle system should be monitored.

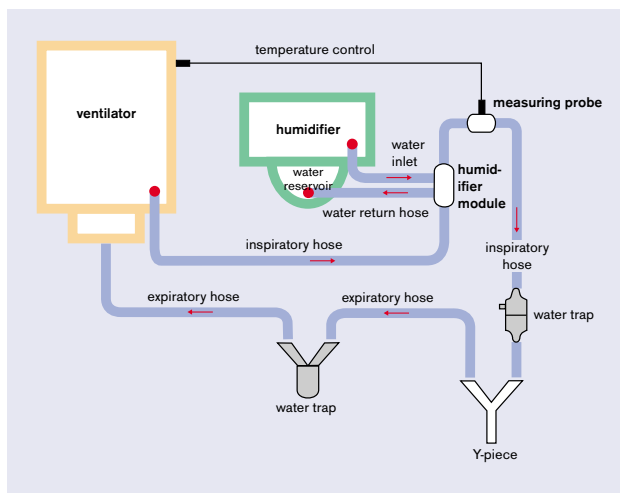

Figure 42: Connecting a humidifier from Fischer & Paykel [BGM]

Heat and moisture exchangers (HME), also called artificial noses, offer a passive alternative to active breathing gas conditioning. They are made of various materials like cellulose, or polyurethane or polyethylene onto which hygroscopic substances have been cultured.

HME absorb warmth and moisture given off by the patient's lungs during expiration and store it (see Figure 43). During inspiration, this is then carried back to the lungs. HME are placed between the Y-piece and the tube and thus increase dead space ventilation (up to 150 ml depending on the manufacturer). They should never be used in combination with active breathing gas humidifiers or medication nebulizers because this would greatly increase the risk of increased respiratory resistance and could lead to complete blockage. There is contradictory information about the tidal volume which must be guaranteed if an artificial nose is to be used on pediatric patients. This information depends both on the manufacturer and the type of filter.

The Humid Vent Mini from the Gibeck-Dryden Corp. is often used for pediatric anesthesia. This filter is well-known for its very low dead space volume (2.4 ml at the tube-breathing system connection) and high efficiency. According to the manufacturer, the filter can be used in a tidal volume range of 10 to 50 ml and produces a humidity of 30 mg/H₂O at a V_T of 20 ml.

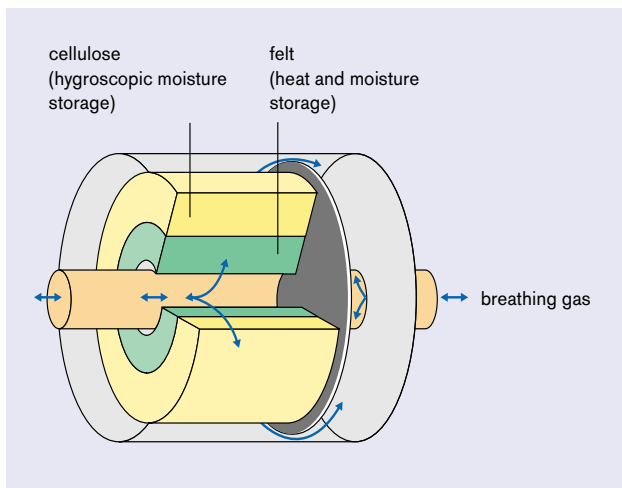

Figure 43:
An HME filter

In a performance comparison of various HME filters and active humidifiers used on pediatric patients between 5 and 30 kg, Bissonnette discovered that, after a short duration, active humidifiers work more efficiently than HME filters. In comparison, the degree of humidity of both systems evens out after a duration of > 80 minutes [Bissonnette, 1989]. Controversial information has been publicized on the amount of additional respiratory work a child has to do when an HME filter is used during spontaneous ventilation [Rodee, 1991].

Due to its volume of approximately 35 ml, the bacterial and conditioning filter Pall Ultipor is only used for pediatric anesthesia when the patient weighs 15 kg or more. The humidifying efficiency of this filter, which decreases when large tidal volumes are used, is 30 mg/L of water at 30 °C for intubated pediatric patients.

	advantages	disadvantages
artificial noses (HME)	<ul style="list-style-type: none"> • safe, no risk of overheating • delivers sufficient moisture • easy to handle • low initial cost • increased microbacterial safety 	<ul style="list-style-type: none"> • blockage due to secretion build-up (greater flow resistance) • direct monitoring not possible • increased resistance in ventilation system (additional dead space) • inflexible as far as variations for humidity and gas temperatures go • limited effectiveness of warming and moistening • not suitable for leaks in the system or for partial rebreathing of expiratory gases
active breathing gas humidifier	<ul style="list-style-type: none"> • delivers sufficiently high moisture levels • as many setting possibilities for humidity and gas temperature as desired • devices suitable for all patients • lower flow resistance • no additional dead space 	<ul style="list-style-type: none"> • risk of infection due to water in the hoses • electrical risks, risk of overheating • additional resistance

Table 25: Advantages and disadvantages of various humidifiers

Heatable Hoses

An alternative to the active humidifier is the passive conditioner in the form of heatable hoses; these have recently been made available for the anesthetic workstations Cicero EM and Cato for use on both pediatric and adult patients. Initial research on heatable hoses tested on adults indicates an obvious improvement to breathing gas condition during low-flow anesthesia. For example, Baum showed that, after the breathing system was pre-warmed and moistened by a previous anesthesia, the level of humidity—already high at 25 mg H₂O (at the beginning of anesthesia)—was able to be raised to 30 and 35 mg H₂O (within one hour) using heatable hoses. Temperatures reached the optimal range of 30 to 37 °C many times during this time. There was no condensation found in the hoses [Baum, 1999].

In addition to the conditioning effect described above, using heatable hoses also provides the advantages of easy handling and an easy preparation phase. A quick response time of five minutes for the hose warming unit was also, in another study, proven to be advantageous with regard to the quick dynamics of body temperature during open-heart surgery on pediatric patients (see Chapter 7.2, PCV during Pediatric Cardio-anesthesia).

The slight loss of gas to environment inherent in the closed system PhysioFlex limits consumption of cold, dry fresh gas during anesthesia. The high blower-supported flow rate also has a thermal stabilizing function and thus optimizes the heat-moisture profile. Wissing reported a humidity level of 20 mg H₂O/l within 10 minutes of beginning anesthesia, and this level was able to be increased shortly thereafter to between 25 and 30 mg H₂O/l. A system temperature of approximately 34 °C and high humidity remain nearly constant due to an efficient CO₂ absorber. Thus, this system does not need an additional HME filter or an active humidifier.

6. Bibliography

Altemeyer, K.-H., Th. Fösel, E. Breucking, F. W. Ahnefeld.
Narkosen im Kindesalter. Rüscher, 1996.

Altemeyer, K.-H.:

Narkosebeatmung-Prinzipien.

Workshop: AK Kinderanästhesie der DGAI 1991.

In: Beatmung von Kindern in Anästhesie und Intensivmedizin.

T. Fösel, G. Kraus. Springer: 1993. p. 36 – 49.

Atemkalk: Hinweise zu korrektem Umgang und fachgerechter Nutzung. Verbandsmitteilungen: Anästhesiologie & Intensivmedizin 6, 1999. 40: 507 – 509.

Badgwell, J. M., J. Tapper.

Ventilating the Pediatric Patient in the Operating Room.

Clinical Practice Bulletin 6.

Dräger Medizintechnik GmbH: 1998.

Baum, J.

Die Inhalationsnarkose mit niedrigem Frischgasfluß.

Thieme: 1998.

Bengtson, J. P., H. Sonander, O. Stenquist.

Preservation of Humidity and Heat of Respiratory Gases during Anaesthesia – A Laboratory Investigation.

Acta Anaesthesiol Scand., 1987. 31: 127 – 131.

BGM.

Atemluft-Befeuchtung in Theorie und Praxis.

Bürk Gesellschaft für Vertrieb und Service von medizinischen Geräten mbH.

Bissonnette, B., D. I. Sessler.

Passive or Active Inspired Gas Humidification Increases Thermal Steady State Temperatures in Anesthetized Infants.

Anesth Analg., 1989. 69: 783 – 787.

Bito, H., Y. Ikeuchi, K. Ikeda.
Effects of the Water Content of Soda Lime on Compound A Concentration in the Anesthesia Circuit in Sevoflurane Anesthesia.
Anesthesiology, 1998. 88 (1): 66 – 70.

Conzen, P.
Muß Halothan ersetzt werden?
Workshop: Neue Pharmaka und Techniken in der Kinderanästhesie. W. Funk and H. Hollnberger. Springer: 1998.

Cote, C. J., E. A. Goldstein, M. A. Cote.
A Single-blind Study of Combined Pulse Oximetry in Children.
Anesthesiology, 1991. 74: 980 – 987.

Davis, G. M., M. A. Bureau.
Pulmonary and Chest Wall Mechanics in the Control of Respiration in the Newborn.
Clinics in Perinatology, 1987. 5: 51 – 79.

Diefenbach, C.
Pharmakologie von Muskelrelaxanzien im Kindesalter.
Workshop: Neue Pharmaka und Techniken in der Kinderanästhesie. W. Funk and H. Hollnberger. Springer: 1998.

Eberhard, M., R. Schäfer .
Klinikleitfaden Anästhesie.
Gustav Fischer Verlag: 1998.

Engström, Edith.
Die natürliche Befeuchtung.
Gambro Engström

Feldman.

Pediatric Ventilation using the Narkomed 6000.
Clinical Practice Bulletin 7.
Dräger Medizintechnik GmbH: 1998.

Förster, H.

Das Soda lime-Problem.
Anaesthesist, 1999. 48: 409 – 416.

Fösel, Th., G.-B. Kraus.

Beatmung von Kindern in Anästhesie und Intensivmedizin.
Springer Verlag: 1993.

Fösel, T., K.-H. Altemeyer, H. Heinrich, P. Lotz.

*Möglichkeiten und Grenzen der Ventilationsüberwachung
bei Narkosen von Säuglingen und Kleinkindern.*
Anaesthesist, 1984. 33: 31 – 38.

Frei, F. J., C. Johmarker, O. Werner.

Kinderanästhesie.
Springer Verlag: 1994.

Frei, Ummenhofer.

Besonderheiten bei der Prä-Oxygenierung von Kindern.
Anästhesiol. Intensivmed. Schmerzther.,
1994. 29: 233 – 235.

Fröhlich, D., B. Schwall, W. Funk, J. Hobbhahn.

*Laryngeal mask airway and uncuffed tracheal tubes are
equally effective for low flow or closed system anaesthesia in
children.*

British Journal of Anaesthesia, 1997. 79: 289 – 292.

Funk, W., H. Hollnberger.
Sevofluran in der Kinderanästhesie.
Neue Pharmaka und Techniken in der Kinderanästhesie.
Springer Verlag: 1998.

Gebhardt, R., U. K. Weiser.
Anaesthesiol Reanim, 1999. 24 (2): 41 – 6.

Gregory, G. A.
Pediatric Anesthesia.
Churchill Livingstone: 1994.

Grüneß, V., W. Wilhelm, Th. Fösel.
Besonderheiten der endotrachealen Intubation beim Kind.
Anästhesiol. Intensivmed. Notfallmed. Schmerzther., 1995.
30: 479 – 482.

Holzki, J.
Changing Aspects of Sevoflurane in Paediatric Anaesthesia: 1975-99.
Paediatric Anaesthesia, 1999. 9: 283 – 286.

Huehns, E. R., E. M. Shooter.
Human Hemoglobins.
J. Med Genet 2, 1965. p. 48.

Igarashi, M., H. Watanabe, H. Iwasaki, A. Namiki.
Clinical Evaluation of Low-flow Sevoflurane Anesthesia for Pediatric Patients.
Acta Anaesthesiologica Scandinavica, 1999. 43: 19 – 23.

Inomata, S., S. Watanabe, M. Taguchi, M. Okada.
End-tidal sevoflurane Concentration for Tracheal Intubation and Minimum Alveolar Concentration in Pediatric Patients.
Anesthesiology, 1994. 80: 93 – 96.

Jaklitsch, R.

Der integrierte Arbeitsplatz für die Kinderanästhesie.
Dräger Medizintechnik aktuell. 2/95.

Jöhr, M.

Kinderanästhesie.

Gustav Fischer Verlag: 1998.

Kleemann, P. P.

Tierexperimentelle und klinische Untersuchungen zum Stellenwert der Klimatisierung anästhetischer Gase im Narkosekreissystem bei Langzeiteingriffen.
Wissenschaftliche Verlagsabteilung. Abbott GmbH:
Wiesbaden, 1989.

Kleemann, P. P.

The Climatisation of Anesthetic Gases under Conditions of High Flow to Low Flow.
Anaesthesist, 1989. Nov/38 (11): 639 – 41.

Krane, Haberkern, Jacobsen.

Postoperative Apnea, Bradycardia and Oxygen Desaturation in Formerly Premature Infants; Prospective Comparison of Spinal and General Anesthesia.
Pediatric Anesthesia 80, 1995. 80: 7 – 13.

Kraus, G.

Konzepte der totalen intravenösen Anästhesie (TIVA).
Workshop: Neue Pharmaka und Techniken in der Kinderanästhesie. W. Funk and H. Hollnberger.
Springer: 1998.

Kretz, F.-J.

Sicherheitsaspekte in der Kinderanästhesie.
Kinderkrankenschwester 13. 1994: 9.

Kretz, F.-J.

Anästhesie, Intensiv- und Notfallmedizin bei Kindern.
Thieme.

Larsen.

Anästhesie.
Urban & Schwarzenberg.

Le Dez, K. M., Lerman J.

The Minimum Alveolar Concentration of Isoflurane in Preterm Neonates.
Anesthesiology, 1987. 67: 301 – 307.

Lotz, P., E. Siegel, D. Spilker.

Grundbegriffe der Beatmung.
GIT Verlag: Darmstadt, 1984.

Loop, T.

Inhalationsanästhesie bei Kindern.
Pharmacia & Upjohn.

McNiece, W. L., G. Krishna.

Kawasaki Disease: A Disease with Anesthetic Implications.
Anesthesiology, 1983. 58: 269 – 271.

Mielke, L., R. Hipp, S. Hargasser, E. Entholzner.

Desfluran in der Kinderanästhesie.

Workshop: Neue Pharmaka und Techniken in der Kinderanästhesie. W. Funk and H. Hollnberger.
Springer: 1998.

Möllhoff, Th., G. Burgard, Th. Prien.

Low-flow Anästhesie während der Beatmung mit der laryngealen Maske.
Anästhesie – allgemein. p. 141.

Mortola, J. P.

Mechanics of Breathing:

Fetal and Neonatal Physiology.

Philadelphia, 1998. p. 1118 – 29.

Nunn, J. F.

Applied Respiratory Physiology.

Butterworths: London, 1987.

Oczenski, W., A. Werba, H. Andel.

Breathing and Mechanical Support.

Blackwell-MZV: 1997.

**Peters, J. W. B., J. Bezstarosti-Van Eeden, W. Erdmann,
E E. Meursing.**

*Safety and Efficacy of Semi-closed Circle Ventilation in
Small Infants.*

Paediatric Anaesthesia, 1998. 8: 299 – 304.

Quasha, A. L., E. L. Eger, J. H. Tinker.

Determinations and Applications of MAC.

Anesthesiology, 1991. 53: 315 – 334.

Rathgeber, J.

Praxis der maschinellen Beatmung.

MCN-Verlag: 1990.

Rathgeber, J.

*Grundlagen und Methoden der Atemgasklimatisierung in
der Intensivmedizin.*

Intensivmedizin, 1995. 32: 448 – 456.

Reinhold, P., G. Kraus, E. Schüttler.

Propofol zur Narkose und Kurzzeitsedierung.

Anaesthesist, 1998. 47: 229 – 237.

Rodee, W. D., M. J. Banner, N. Gravenstein.
*Variation in Imposed Work of Breathing with Heat and
Moisture Exchangers.*
Anesth Analg, 1989. 72: 226.

Rupp, K., E. Siegel.
Atempause?
Dräger Medizintechnik aktuell 1/98.

Schäfer, R., Barthel M. Gerlach, P. Schmucker.
*Auswirkungen endoskopischer Operationstechniken bei
Kindern auf die Beatmung.*
Anästhesiol. Intensivmed. Notfallmed. Schmerzther., 1997.
32: 343 – 347.

Schirmer, U., M. Schreiber, A. Goertz, W. Schütz, M.
Georgieff, Rockemann.
*Einfluß von Störungen der Lungencompliance auf die Ven-
tilation von Neugeborenen.*
Anaesthesist, 1994. 43: 521 – 527.

Schirmer, U., J. Villwock, T. Fösel, M. Schreiber, A. Goertz,
M. Georgieff.
*Untersuchung von Einflußgrößen auf das abgegebene Hub-
volumen.*
Anästhesist, 1992. 41: 785 – 789.

Schreiber, G., W. Heß, A. Marichal.
*Der Einfluß verschiedener Narkosebeatmungsverfahren auf
Oxygenierung und Ventilation von Säuglingen.*
Anaesthesist, 1994. 43: 510 – 520.

Shann, F., S. Gatchalian, R. Hutchinson.

Nasopharyngeal Oxygen in Children.

Lancet, 1988. 2: 1238 – 1240.

Spears, R. S., A. Yeh, D. M. Fischer.

The Educated Hand: Can Anesthesiologists Assess Changes in Neonatal Pulmonary Compliance Manually?

Anesthesiology, 1991. 75: 693 – 696.

Stevenson, G. W., M. Tobin, B. Horn, E. Chen, S. C. Hall, C. J. Cote.

An Adult System Versus a Bain System:

Comparative Ability to Deliver Minute Ventilation to an Infant Lung Model with Pressure-limited Ventilation.

Anesth Analg, 1999. 88: 527 – 530.

Strauß, Hausdörfer, Hagemann, Schröder.

Klimatisierung anästhetischer Gase während Säuglingsnarkosen mit dem Anästhesiarbeitsplatz Cicero.

Anaesthesist, 1992. 41: 534 – 538.

Suprane.

Edmond I Eger II.

Pharmacia & Upjohn: 1994.

Versmold, H. T.

Pediatrics, 1981. 67: 607.

Wawersik, J.

Respiratorische Probleme bei der Säuglingsnarkose.

In: Der Risikopatient in der Anästhesie. 2. Respiratorische Störungen.

F.W. Ahnefeld, H. Bergmann, C. Burri, W. Dick, M.

Halmugvi, E. Rügheimer,

eds. Springer Verlag: Klinische Anästhesiologie und Intensivmedizin, 1976. 12: 163 – 177.

Weiser, U.-K.

Praktische Erfahrungen mit Narkoseverfahren bei reduziertem Frischgasflow.

In: Beatmung von Kindern in Anästhesie und Intensivmedizin. T. Fösel, G. Kraus, eds.

Springer: 1993. p. 36 – 49.

7. Practical Application

7.1 Anesthetic Ventilation for Infants and Small Children

Dr. Holzki, Children's Clinic, Cologne, Germany

Ventilating premature infants, newborns and small children during an operation, whether an operation of short or long duration, usually means ventilating lungs which are not only immature, but also often anatomically modified as a result of some damage, be it from maturing too quickly, a lack of surfactant, oxygen use or long-term ventilation.

Ventilating these pediatric patients calls not only for a technique which will ensure that the patient survives the anesthesia, it also calls for a technique which neither stresses the very vulnerable lungs of these children unnecessarily, nor worsens the lungs' already damaged structure. Even inadequate ventilation of short duration during anesthesia can lengthen the process of weaning pediatric patients from the respirator by days or weeks.

Otherwise "healthy" premature infants and "normal" newborns also have immature lung structures. The count of alveoli, for instance, is about 50 million for a full-term newborn; this number increases during the first month to about 150 million (1). The amount of surfactant, that substance which keeps the alveoli from collapsing, is usually insufficient and it can be very easily destroyed by high concentrations of oxygen, infections of the bronchial mucus membrane and lung tissue (e.g. aspiration pneumonia), as well as manipulation of the respiratory tract. Atelectasis development leads to insufficient ventilation which in turn necessitates artificial respiration.

If these immature lungs have to be ventilated in combination with anesthetics, the anesthesia itself could cause additional problems, like reducing the functional residual capacity of the lungs (FRC), disturbing the distribution process of ventilation and perfusion in many parts of the lungs, thus increasing the physiological dead space to the point that anesthetic ventilation must be initiated using a tidal volume of 10 to 15 ml/kg. This is clearly a higher value than that of spontaneous breathing (2). If inadequate ventilation techniques are applied, above all inadequate pressure-volume loads, a vicious circle of damage may occur in which structural changes of lung tissue, or even a cor pulmonale, could lead to death (3).

About the twenty-fifth week after conception, a premature infant is able to breath, spontaneously, sufficiently. Each ventilation process required, even if it only has to be carried out as a result of apnea, meets with alveoli of varying compliance, reduced elastic fibers with insufficient surfactant, a very fragile ductus alveolares structure, and a very elastic rib cage which yields without resistance to the inspiratory pressure of the respirator. These poor anatomical conditions can lead to regional overinflation, tears in the ductus alveolares and subsequent interstitial emphysema. These sorts of damage necessitate higher concentrations of oxygen and can, in the end, lead to chronic lung damage called bronchopulmonary dysplasia (BPD (4)), (Figure 1).

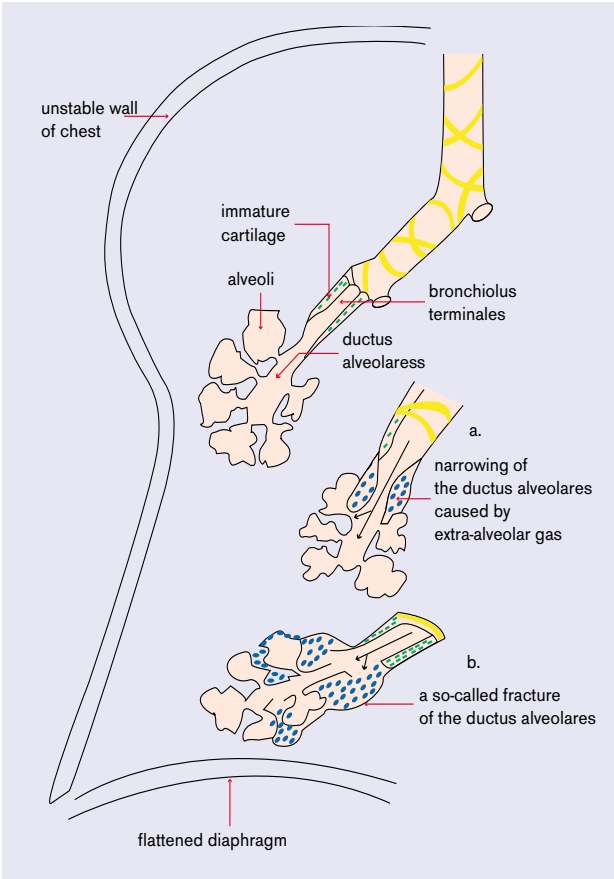

Figure 1: The lungs of all patients having BPD, as well as the lungs of premature newborns and neonates, which are fragile as well as regionally and structurally very different in their stages of maturity, can be over-inflated or torn by a sudden inspiratory phase; air bubbles are dispersed in the submucosa of the ductus alveolares (a) and cause interstitial emphysema (b), leading to pneumomediastinum, pneumopericardium, and pneumothorax.

Danger to the lungs does decrease as the pediatric patient matures, but the strategies necessary to avoid causing BPD remain relevant for children of all ages, especially during anesthesia.

In some rare cases, premature infants and newborns can only undergo anesthesia if a lack of surfactant has been replaced by artificial means. Since a single surfactant administration is often not enough to stabilize the alveoli for good, it is of utmost importance to ensure that the lungs provide sufficient gas exchange several hours prior to the operation, for if a relapse occurs during anesthesia, the consequences can be deadly.

Even if the individual patho-physiological steps leading to the development of chronic lung diseases are still the topic of controversial discussion, the importance of ventilation as a prime factor leading to damage in the form of BPD is no longer contested. An incorrect ventilation technique can stop the process of alveolar development. For this reason, only that ventilation technique is acceptable which causes the least baro- or volume trauma for each respective patient.

When the thorax of a premature infant is open, even the slightest regional overinflation of the lungs can be seen on X-rays for weeks (a personal observation). This demonstrates the importance of a good ventilation strategy for pediatric anesthesia, especially for the youngest of pediatric patients, and even if the anesthesia is only part of what is already long-term ventilation.

A pediatric anesthetist is confronted with a variety of patients and, in addition to immature lungs, must often contend with disturbances in respiratory regulation, atelectasis due to aspiration pneumonia, occasional esophago-tracheal fistulas, hypoplastic lungs, or thorax deformations which, initially, do not cause any damage to the tissue structure of the lungs. The pediatric anesthetist must inevitably, for these cases also, use internationally established standards for neonatal ventilation during anesthesia.

From the very beginning of IMV ventilation for babies, the primary, most adequate method of artificial ventilation of pediatric patients was, and still is, the kind of ventilation which allows the inspiratory and expiratory phases, and set pressure to be individually controlled. After the epoch-making discovery by Gregory in 1971 (5), the use of continuously applied airway pressure (CPAP) between 2 and 10 cm H₂O has become a basic rule to be used whenever premature infants or newborns are ventilated. This means that there is a continuous flow of gas during ventilation, even during expiration, which maintains previously set positive airway pressure and prevents the alveoli from collapsing. This method allows the patient to take a spontaneous breath at any time. This form of ventilation was titled “intermittent mandatory ventilation”, or IMV, and is the basic form of ventilating today (Figure 2).

Figure 2: Example of an individually set respiratory stroke during IMV using a time-cycled device (e.g. Babylog N)

A ventilation pattern, which exactly responds to the anatomical and physiological quirks of a specific patient's lungs, can be set in the respirator by using a variable gas flow and a time limit for this gas flow. In addition to Babylog N, this ventilation mode can best be carried out using the PhysioFlex anesthetic machine equipped with an Alice System.

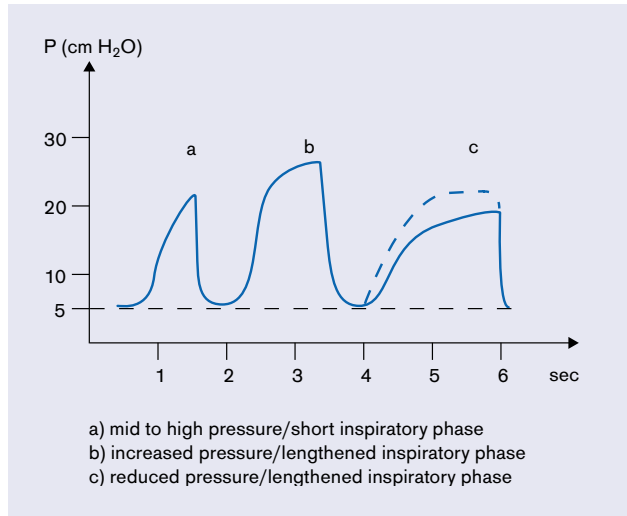

New additions to ventilation strategies include a few procedures for weaning patients from the respirator, like synchronized IMV (SIMV), pressure-supported and minute volume guaranteed techniques, as well as the proportional assistance method. These strategies are of secondary importance for anesthetic ventilation since ventilation is always controlled during anesthesia. Pediatric anesthesiologists do, however, need to be familiar with these techniques in order to supervise postoperative ventilation.

There is, according to definition, a fundamental difference between CPAP and positive end-expiratory pressure (PEEP) which has consequences for clinical practice. During the CPAP ventilation mode, airway pressure does not fall below the set positive value because gas is continuously regulated and added accordingly. If, however, PEEP is the set parameter, for instance during IPPV, the only thing certain is that airway pressure will be positive at the end of the expiratory phase while the beginning and middle of this phase can vary, or even be negative since there is no additional gas added to the system (Figure 3). Modern anesthetic machines set off alarms in this case. Contrary to popular opinion, collapsed alveoli cannot be re-inflated by using PEEP or CPAP. These methods can only prevent alveoli, previously inflated with high pressure (approx. 15 to 25 cm H₂O), from collapsing.

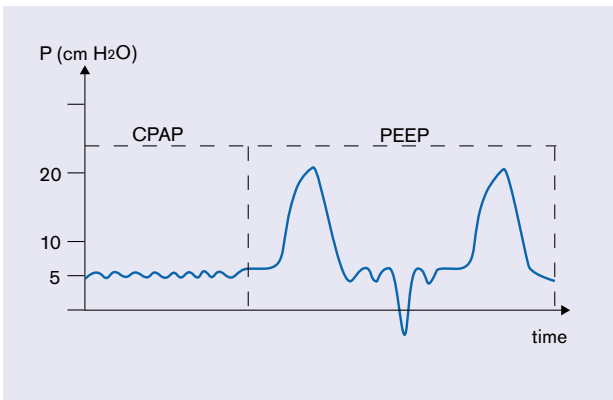

Figure 3: The difference between CPAP and PEEP
 During CPAP, positive airway pressure varies due to small pressure changes caused by spontaneous breathing. On the other hand, when PEEP is carried out with time-cycled devices of older generations (e.g. Babylog N), negative airway pressures can occur before the end of the expiratory phase due to, for example, hiccups, gasping, or outside traction. These disturb the effect of the ventilation process on the lungs.

The first device to use IMV and to be globally employed for ventilating premature infants was the Babybird, a device developed by Robert Kirby (6). IMV combines PCV with CPAP and is most important as a tool for use during the weaning phase, i.e. after long-term ventilation.

Due to its wide-spread acceptance, Babybird was also employed as a respirator for anesthesia, nitrous oxide replacing air. In this way, the ventilation form carried out during anesthesia could remain the same as that carried out prior to the operation or after the operation in the intensive care unit. IMV can be used advantageously at the end of anesthesia after spontaneous breathing has been initiated.

In German-speaking areas, Babybird was an anesthetic respirator of less importance because anesthetists were less familiar with long-term ventilation for newborns and small children. Babylog N from Dräger, which was similar, was somewhat more significant but then again, only used by specially trained pediatric anesthetists.

Why was –and is– PCV, or IMV, so important to pediatric anesthesia?

The respiratory pressures required for PCV are lesser, more average pressures than those required for IPPV (intermittent positive pressure ventilation, see Figure 2 and Figure 4). Besides that, the gas flow in the lungs can be more individually adapted to the patient by changing the rate of increase for the inspiratory curve and of the inspiratory plateau pressure. Pressure control prevents overinflation of the alveoli when the thorax is compressed from the outside. Clinical experience has proven these considerations many times over (7, 8, 9, 10, 11).

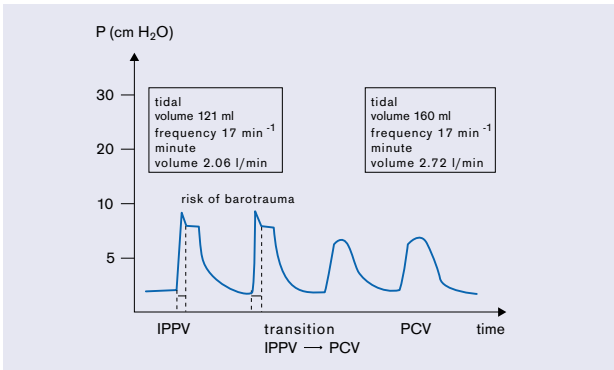

Figure 4: Comparing IPPV and PCV modes carried out using the same plateau pressure and the PhysioFlex anesthetic machine

During IPPV, a given peak pressure builds up quickly and disperses to various parts of the lungs in different amounts with different compliance according to the airway resistance present. During the time it takes to reach the plateau, the risk of extra-alveolar air accumulation is especially high. If plateau pressure is the same everywhere, ventilation in PCV is higher than ventilation in IPPV.

The pressure gradient is set by setting the peak inspiratory pressure (PIP). PIP causes the alveoli to be ventilated and is set according to auscultatory noise and inspection of the thoracic excursion. Each time PIP, or the inspiratory phase, is adjusted these two parameters have to be re-analyzed in order to be able to judge the adequacy of ventilation and to prevent overinflation of the lungs. That means that sufficient experience with pediatric ventilation is absolutely necessary for pediatric anesthesia. Ventilation charts according to age and weight are, at best, only advisable for rough respirator pre-settings.

If tidal volume is preset on a volume-controlled respirator, the effects of ventilation on lung structure can only be poorly assessed. As early as 1977, Kirby pointed out that volume-controlled ventilation is unfavorable for very young children whose very small respiratory tract has to receive and cushion crucial respiratory pressure (“volume controlled is a myth in neonatal ventilation,” (12)). This statement is supported by an observation of D. Null who has very often seen tears in mucus membrane at the terminal respiratory tract which he describes as “fractures of the ductus alveolares” (13). Apparently, volume-controlled ventilation has often left the lung structure in a state of overinflation, interstitial emphysema, or with infections caused by trauma and recorded as a BPD (Figure 5).

Regardless of the type of ventilation, PEEP should be set to within a range of 2 to 5 cm H₂O in order to prevent the alveoli from collapsing during expiration. PEEP corresponds to CPAP during controlled ventilation on a relaxed patient. A higher PEEP (6 to 12 cm H₂O) can impede compliance and thus, hinder ventilation if the indications which make such a high value necessary are not absolutely clear. PIP increases during volume-controlled ventilation.



Figure 5: X-rays of the thoraxes of three infants

- Bronchopulmonary dysplasia after several weeks of ventilation (a)
- Pneumomediastinum and pneumothorax, left, during IPPV (b)
- Pneumopericardium during IPPV (c)

These kinds of ventilation complications were seen on a daily basis before IMV became the more common practice (1975 – 1977) as a result of IPPV used on very young children.



The respiratory rate changes the ventilation rate of the alveoli, but it also changes the ratio of inspiratory to expiratory time (I:E ratio). There is a sufficient amount of empirical numbers available for and helpful in setting the respiratory rate for the lungs of a newborn. Rates greater than 60/min can easily lead to air being trapped and, thus, to barotrauma. The I:E ratio is not a good parameter for regulating ventilation and oxygenation on very young children due to their erratic respiratory rates. Adapting an actual inspiratory phase to the needs of individual lungs has proven to be much better. It has also been empirically proven that inspiratory phases longer than 0.6 seconds only increase oxygenation temporarily, but then they can often lead to pneumothorax due to reduced venous backflow while inspiratory phases shorter than 0.2 seconds often provide only partial ventilation to the alveoli.

Those who wish to carry out optimal anesthetic ventilation on pediatric patients inevitably have to learn the fundamentals of neonatal ventilation techniques and then apply them to situations in the operating theater. Throughout an operation, additional techniques and monitoring parameters are desirable to provide more exact indications of how the lungs are actually functioning and a clear picture of the concentrations of anesthetic gases, which should not escape into the operating theater at all if possible.

Today, the question is which anesthetic respirator should be used to ventilate premature infants and newborns in the future? Older devices like Babylog N are not equipped with the gas monitoring necessary for the future and, at the same time, the latest generation of neonatal respirators cannot be adapted for anesthetic use.

The PhysioFlex anesthetic system provides one possibility, even if it is not yet ready to use on premature infants. Technological development, already proven exceptional for patients weighing over 5 kilograms, is underway for patients under 3 kilograms. Using PhysioFlex with a software program for ventilating small children, PCV can be carried out in this closed system which is almost equivalent to regular IMV. The end-expiratory CO₂ measurement lies below the known limits for young children, but if ventilation is carried out almost leak-free, oxygen consumption is measured indirectly. This measurement can provide the anesthetist with valuable information which was, up till now, not available during anesthesia. For instance, an acute increase in oxygen consumption could be an indication of insufficient depth of anesthesia or it could be –depending on the patient's state of health– an indication of an imminent asthma attack (personal observation).

One can hope that closed-system PCV is available in the near future for use on premature infants.

Anesthetic ventilation for pediatric patients will most likely always prove a great challenge to all practicing anesthetists.

Bibliography

- (1) Langston, C., et al.
Human Lung Growth in Late Gestation and in the Neonate.
Am Rev Resp Dis, 1984. 129: 607 – 611.

- (2) Motoyama, E. K.
Respiratory Physiology in Infants and Children.
In: Anesthesia for Infants and Children.
6th edition. E. K. Motoyama, P. J. Davis, eds. 1996. p. 11 – 68.

- (3) Bancalari, E.
Neonatal Chronic Lung Disease.
In: Neonatal-Perinatal Medicine. 6th edition.
A. A. Fanaroff, R. J. Martin, eds.
Mosby: St. Louis, 1997. p. 1074 – 1089.

- (4) Martin, R. J., Fanaroff, A. A.
The Respiratory Distress Syndrome and its Management.
In: Neonatal-Perinatal Medicine. 6th edition.
A. A. Fanaroff, R. J. Martin, eds. 1998. p. 1018 – 1028.

- (5) Gregory, G. A., J. A. Kitterman, R. H. Phibbs, et al.
Treatment of the Idiopathic Respiratory Distress Syndrome with Continuous Positive Airway Pressure.
New England Journal of Medicine, 1971. 284: 1333 – 1339.

- (6) Kirby, R. R.
Design of Mechanical Ventilators.
D. W. Thibeault, G. A. Gregory, eds. Addison-Wesley Publishing Co.: Menlo Park, Ca., 1979. p. 154 – 167.

- (7) Reynolds, E. O. R., et al.
Improved Prognosis of Infants Mechanically Ventilated for Hyaline Membrane Disease.
Arch Dis Child, 1970. 49: 505 – 510.
- (8) Boros, S. J.
Variations in Inspiratory : Expiratory Ratio and Airway Pressure Wave Form during Mechanical Ventilation: The Significance of Mean Airway Pressure.
J Pediatr., 1979. 94: 114 – 119.
- (9) Bancalari, E., J. C. Sinclair.
In: Effective Care of the Newborn Infant.
J. C. Sinclair, ed. Oxford University Press:
New York, 1992.
- (10) Carlo, W. A., R. J. Martin, A. A. Fanaroff.
Assisted Ventilation and Complications of Respiratory Distress.
In: Neonatal-Perinatal Medicine. 6th edition. A. A. Fanaroff, R. J. Martin, eds. Mosby: St. Louis, 1998. p. 1028 – 1036.
- (11) Holzki, J.
Kongressberichte über das 4.-26. Neonatal and Infant Respiratory Symposium. AINS: 1977 – 1999.
- (12) Kirby, R.
In: Kongressbericht über das 4. Neonatal and Infant Respiratory Symposium. J. Holzki, ed.
Prakt Anästh, 1977. 12: 541-555.
- (13) Null, D. M.
In: Kongressbericht über das 20. Neonatal and Infant Respiratory Symposium. J. Holzki, ed.
AINS: 1993. 28: 394 – 397.

7.2 PCV during Pediatric Cardio-anesthesia

Dr. Fischer, German Center for Cardiology, Berlin

Pediatric cardio-anesthesia has a spectrum which includes correcting congenital defects (cyanotic, acyanotic), transplantation surgery (heart and lung) and related illnesses (e.g. cystic fibrosis, Wilson-Mikity syndrome), both by employing and not employing extracorporeal circulation (ECC). Extracardia deformities (VACTERL association, asplenia syndrome, Ivemark's syndrome), which usually go along with a congenital defect, are particularly challenging to anesthetists.

Since the heart and lungs represent a single functioning unit, mechanical ventilation has an effect on (partially) varying hemodynamics (e.g. fontanel hemodynamics), before and after correcting a congenital defect, which should not be underestimated.

Using ECC to correct congenital defects, which could lead to capillary leak syndrome (alveolar capillary leakage), also places additional emphasis on the necessity of sufficient ventilation.

As a result of this, the following prerequisites for anesthetic respirators can be derived:

- large variables for tidal volume and respiratory rate due to greater distribution of age
- low dead space volume
- avoiding high ventilating pressures (e.g. fontanel operative procedures)
- reliable monitoring for ventilation parameters and capnography (pulmonary hypertension caused by hypoventilation)
- valid capnogram for regulating pulmonary vascular resistance (e.g. HLHS, shunt defects)
- sufficient breathing gas conditioning

In the past, pressure and time-cycled respirators (Bird[®], Penlon[®], Babylog N[®]) were used for mechanical ventilation in pediatric cardio-anesthesia. The disadvantage of these respirators –the volumes provided were inconsistent– was compensated for by the introduction of volume- and time-cycled devices in the middle of the 1980s (SERVO 900[®], Sulla 800[®]). These devices, developed for adult patients, do, however, have a few disadvantages when used for pediatric anesthesia, like large dead space volume and compressible volume. The latest generation of anesthetic machines (Cicero[®], Cato[®], Julian[®], Aestiva[®], Kion[®]) allow anesthetists to use both pressure- and volume-controlled ventilation modes.

At our Heart Center, we use a Cato-PCV anesthetic respirator (from Dräger, Germany) which has active hose warming (see the section on Conditioning Breathing Gas for Children). The properties associated with the various ventilation forms (IPPV/VCV, PCV) were discussed in a previous chapter (see Chapter 5.1, Mechanical Forms of Ventilation). As far as the form of ventilation is concerned, we use volume-controlled ventilation (IPPV, V_T 10 to 1400 ml, respiratory rate 6 to 80) before employing extracorporeal circulation and PCV afterwards.

Advantages of the PCV ventilation mode

- lower respiratory pressure (approx. 2 mbar under IPPV peak pressure)
- no accidental overinflation of the lungs when the thorax is open
- better alveolar recruitment due to decelerated flow

Disadvantages of the PCV ventilation mode

- V_T changes when thorax compliance is changed (surgical manipulation, closed thorax), P_{max} is the same for both

For this reason, when pressure-controlled ventilation is used, alarm limits (MV) should be set conservatively and the tidal volume should be continuously displayed by the volumeter.

PCV is used either before or after ECC for ductus ligation and pulmonary diseases which can severely influence hemodynamics as a result of high peak pressures occurring during ventilation (restrictive lung disease, after fontanel operative procedures).

Special features of these two forms of ventilation can be summed up as follows:

Volume-controlled and time-cycled ventilation (VCV)

The greatest disadvantage of VCV is limited consistency in tidal volume (tube leakage) which puts the patient at risk of barotrauma due to a change in pulmonary compliance, an increase of compression volume due to the deterioration of pulmonary compliance, and lung overinflation. By introducing static compliance correction, it is at least possible to set a simple tidal volume.

Pressure-controlled and time-cycled ventilation (PCV)

The advantages of PCV include avoiding peak pressures during ventilation (barotrauma), decelerating flow, compensating for tube leakage, and providing static compliance for newborns and infants with low tidal volumes. The big disadvantage caused by the dependency between tidal volume and a varying lung compliance requires the anesthetist to be very attentive to the situation, but can be controlled by using adequate monitoring (V_T , MV).

Conditioning Breathing Gas for Children

In a joint venture with Dräger of Lübeck, Germany, our Heart Center integrated a heatable hose system into the respirator system of a Cato anesthetic workstation. A temperature sensor was added to the inspiratory hose at a point close to the patient, and a bacterial filter was added to the inspiratory and expiratory limbs of the circle system.

Over a period of six months, this hose system was used in 261 congenital defects operations. The ages of the pediatric patients were less than five (0 to 5 years), and a large portion of these children (> 60 %) were younger than three months. The minute volume was between 1 and 2 l/min. Since sevoflurane was always used, low-flow anesthesia was not used and the MV fresh-gas flow was adapted accordingly up to a maximum of 2 l/min.

The aim of this research into usability was to find an easy-to-handle hose warmer which sufficiently humidifies breathing gas, not putting the small patients at unnecessary risk.

Results

The hose system, used over six months in 261 operations, did not fail unexpectedly. Breathing gas temperatures, central and peripheral body temperature and room temperature were recorded for 20 children with the hose warming system and for 10 children without it.

As far as body temperature dynamics during open-heart surgery are concerned (cooling down to a body temperature of 16 °C, warming up to 36 °C due to heart-lung machines, room temperatures originally at 16 °C and after ECC up to 22 °C), the hose warmer was able to adjust the hoses sufficiently within five minutes without any dangerous "hot spots" appearing. The course of the operation being smooth, all 20 children had constant body temperatures before and after ECC. Breathing gas temperatures before ECC (room temperature at 16 °C), as well as after ECC (room temperature at 22 °C), were at 30 °C within five minutes of IPPV beginning (with temperatures ranging between 28 and 32 °C). In comparison, the circle system itself warms up without the integrated hose system only after 30 minutes and only up to a maximum of 22 °C (temperatures here range between 20 and 24 °C) and it exhibits condensation build-up after one to two hours of anesthesia administration, indicating that the pediatric patient has suffered loss of liquid and loss of water.

Advantages of active hose warming systems over active humidification systems

- easy to handle and clean
- rapid rise in temperature without hot spots appearing during high-flow pediatric anesthesia (fresh-gas flow 2 l/min)
- reduced risk of disconnection
- by not having condensation, no bacterial contamination or drowning of pediatric patient
- cost reductions through recycling

Advantages of active hose warming systems over heat-moisture exchangers (HME)

- dead space does not increase
- airway resistance does not increase
- no secretion and/or tube obstructions
- quick reactions
- cost reducing

In conclusion one could say that PCV is highly valued, as far as the quality of ventilation is concerned, for ventilating critically ill infants and children.

Bibliography

Bernstein, G., et al.

Airway Leak Size in Neonates and Autocycling of Three Flow-triggered Ventilators.

Crit Care Med., 1995. 23 (10): 1739 – 44.

Bourdelles, G., L. Mier, B. Fiquet, G. Saumon, D. Dreyfuss.
Comparison of the Effect of Heat and Moisture Exchangers and Heated Humidifiers on Ventilation and Gas Exchange during Weaning Trials from Mechanical Ventilation.

Chest, 1996. 110: 1294 – 98.

Konrad, F., M. Mezody, A. Goertz, T. Marx, M. Georgieff.

Einfluß eines Wärme und Feuchtigkeitsaustauscher (HME) auf den bronchialen Schleimtransport im Rückatemnarkosesystem.

Anaesthesist, 1996. 45: 802 – 06.

Nikitin, E. S., et al.

The Use of a Pressure Support Ventilation Regimen in the Recovery of Spontaneous Respiration after Heart Operations.

Anesthesiol Reanimatol, 1998. 8 (4): 31 – 6.

Marini, J. J.

New Options for the Ventilatory Management of Acute Lung Injury.

New Horizons: 1993. 1: 489 – 503.

Martin, L. D., et al.

New Approaches to Ventilation in Infants and Children.

Curr Opin Pediatr., 1995. 7: 253.

Pollak, M. M., et al.

Pneumothorax and Pneumomediastinum during Pediatric Mechanical Ventilation.

Crit Care Med., 1979. 7: 536 - 539.

Rathgeber, J., W. Weyland, T. Bettka, K. Züchner, D. Kettler.
Is Reduction of Intraoperative Heat Loss and Management of Hypothermic Patients with Anesthetics Gas Climate Advisable? Heat and Humidity Exchangers vs. Humidifiers in a Functional Lung Model.

Anaesthesist, 1996. 45: 807 - 13.

Rawlings, D. J., et al.

The Siemens-Elima Servo Ventilator 900 B for the Management of Newborns with Severe Respiratory Distress Syndrome.

Crit Care Med., 1980. 8 (5): 307 - 11.

Sugg, B. R., et al.

The Penlon Oxford Ventilator. A New Ventilator for Adult or Pediatric Use.

Anaesthesia, 1976. 31(9): 1234 - 44.

7.3 Using a Laryngeal Mask for Pediatric Anesthesia

Dr. Keller, Leopold-Franzens University, Innsbruck

In 1981, Archie Brain, a British anesthesiologist, developed the laryngeal mask (LMA) within the scope of a research project at the Royal London Hospital which aimed at finding a user-friendlier airway than the face mask and a less invasive one than the endotracheal tube. Within the last eight years, the LMA has become a universal airway generally used for performing routine pediatric anesthesia. The LMA, available in various sizes (see below, Table 1), is used in 30 to 60 % of all anesthesia cases. It is used particularly for those cases which require a face mask, but not for those cases in which an endotracheal tube is advisable. Those factors indicating an unfavorable situation for LMA use are described further below.

To date, the LMA has been handled in more than 1,600 publications and used on more than 50 million anesthesia patients (pediatric and adult) in at least 90 countries. In more than six years, there have been no known reports of death caused by the use of the laryngeal mask.

Table 1: Various LMA sizes

LMA size	weight of patient (kg)	length of tube (cm)	ID* (mm)	max. cuff vol. (ml)	largest ETT** (ID*, mm)	FOB*** (mm)
1	< 5	8	5.25	< 4	3.5	2.7
1.5	5–10	10	6,1	< 7	4.0	3.0
2	10–20	11	7.0	< 10	4.5	3.5
2.5	20–30	12.5	8.4	< 14	5.0	4.0
3	30–50	16	10	< 20	6.0 (cuff)	5.0
4	50–70	16	10	< 30	6.0 (cuff)	5.0
5	> 70	18	11.5	< 40	7.0 (cuff)	7.3

* ID = inside diameter, ** ETT = endotracheal tube

*** FOB = fiberoptic bronchoscope

Contraindications for Pediatric LMAs

Patient-related factors which increase the risk of aspiration:

- gastric content
- upper gastrointestinal pathology
- pathological obesity
- large amounts of pain
- anamnesis unattainable
- gastrointestinal obstructions
- residual gastric content or delayed reduction due to opiates

Operation-related factors which increase the risk of pulmonary aspiration:

- upper stomach surgery
- peritoneal traction
- increased intra-abdominal pressure
- head tilted back in the extreme

High respiratory pressure (> 20 mbar):

- low lung and thorax compliance
- high airway resistance
- pathological glottis (ray treatment of the larynx or pharynx)
- intrathoracic surgery

Pathological mouth or pharynx (for example, anamnestic radiotherapy)

Blood anamnesis (relative)

Anesthesia Induction

If added to an induction dose, Propofol subdues pharyngeal and laryngeal activity more than Thiopental and it is considered an excellent induction agent. Taguchi and colleagues have shown that a lower sevoflurane MAC value is required while LMAs are being positioned on pediatric patients than is the case when an endotracheal tube is being inserted.

Laryngeal Mask Insertion

The ideal patient position for inserting an LMA is an extended head and flexed neck, the classic “sniff-the-morning-air” position. This position is attained by tilting the head of the patient backwards and downward during the insertion movement using the non-dominant hand. LMA insertion can be compared to the act of swallowing. The mask can be inserted blind and without administering muscle relaxants, and a collision with the front of the pharynx with its numerous nerve endings is simultaneously avoided. When a person swallows, the tongue pushes nourishment along the curved wall made up of the palate and the back part of the pharynx and then pushes it down. An LMA insertion is accomplished in a similar way: the index finger pushes the mask upwards, thus imitating the tongue when it pushes the food along the palate. That means that the anesthetist holds his finger pointed toward his bellybutton throughout the insertion maneuver. The mask is completely inserted as soon as definite resistance is noticeable. This resistance is the result of the tip of the mask meeting the top of the esophageal sphincter. The most common error made during the insertion phase is that the centrifugal force of the index finger exerted against the curve of the hard palate and the back of the oropharynx is not kept constant long enough for the LMA to reach the hypopharynx.

It is important to differentiate between pressure in the cuff, the pressure the cuff places on the mucosa, and the airway pressure which could be the source of leakage. One of the LMA cuff's most important functions during spontaneous breathing is to protect the larynx from oropharyngeal secretions. In order to carry out this function, an oropharyngeal pressure of up to 10 mbar is necessary. Tension in the cuff should be checked regularly. It could become necessary to let off slight amounts of air because the pressure in the cuff increases as a result of nitrous oxide diffusion.

Maintaining Depth of Anesthesia

A combination of regional and inhalation anesthesia (O_2 / N_2O , sevoflurane or isoflurane) for spontaneous breathing with inspiratory pressure support ("hand on the bag") or pure CPAP ventilation is most common. At the same time however, most children with no gastric content can be mechanically ventilated in the IPPV mode over the LMA using normal lung compliance with a maximum airway peak pressure of approx. 20 mbar (see below, Table 2, Dräger respirator setups). Having a low-pressure seal means that tidal volume is about 6 – 8 ml kg^{-1} and that the inspiratory flow should be reduced in order to ensure safe and sufficient ventilation. An epigastria auscultation should be performed on all children to prevent stomach insufflation. Several large-scale studies have confirmed the safeness of using IPPV with the LMA on both adults and children. A meta-analysis of 547 publications dealing with LMAs did not show any correlation between IPPV and pulmonary aspiration, either in patients from LMA studies or in patients from case reports on aspiration.

Table 2: Dräger respirator setups

IPPV with Cato or Julian from Dräger	
tidal volume	6 to 8 ml kg ⁻¹
respiratory rate	as per etCO ₂
I:E	1:1
pressure limit Pmax	< 20 mbar
PEEP	if necessary, 5 mbar
epigastric auscultation	yes
PCV with Cato or Julian from Dräger	
pressure limit	< LMA snugness (usually 8–15 mbar)
respiratory rate	as per etCO ₂
I:E	1:1
PEEP	if necessary, 5 mbar
inspiratory flow	as low as possible*
epigastric auscultation	yes
ASB** better than CPAP only with Evita from Dräger	
inspiratory pressure support	5 mbar
PEEP	if necessary, 5 mbar

* The inspiratory flow should be set high enough to reach the pressure limit (see Chapter 5.1.3, The Ventilation Mode PCV).

** Assisted spontaneous breathing

Removing the LMA

The LMA may be removed when the pediatric patient is still under anesthesia or awake, and while the patient is laying on its back or side. The mask should not be removed when the patient is going through a transition stage as this could lead to laryngospasm, coughing or choking. The child should not be disturbed by the LMA when waking up. It is not necessary to use suction to remove secretions around the upper pharynx since they will not enter the larynx unless the cuff is unblocked before the LMA is removed. The cuff should be unblocked at the same time the LMA is removed.

Advantages and Disadvantages of Using the Laryngeal Mask

Advantages of the laryngeal mask over the face mask include the availability of a freer respiratory tract which frees the hands of the anesthetist for other important tasks, like administering medication and preparing documentation. It is also easier to obtain an effective, air-tight closure which facilitates ventilation and improves monitoring for breathing gas mixtures and low-flow anesthesia. The quality of the airway is generally unaffected by anatomical factors which complicate matters when a face mask is used, i.e. due to the patient's being toothless or having a beard or being a newborn. Using an LMA as opposed to a face mask does not require personnel which is still being trained or does not yet have a lot of clinical experience to be extremely skilled.

Comparative analyses of face masks report that hypoxia is rare in conjunction with the LMA. In addition, LMAs offer direct access to the glottis without sacrificing control of the airway and thus, make it easier to see and get at both the vocal chords and a larger part of the respiratory tract. The LMA also poses less environmental risk to the operating theater and recovery room.

The advantages of the laryngeal mask as compared to the tracheal tube include being able to do without laryngoscopy, being less invasive to the respiratory tract, avoiding the risks associated with endobronchial or esophageal intubation, being able to do without muscle relaxants, and relieving local tissue of a good portion of trauma. Learning to position a laryngeal mask is easy and, generally speaking, not associated with those factors which make inserting an endotracheal tube difficult. Pediatric patients tolerate an LMA at a more shallow depth of anesthesia than they do an endotracheal tube and are usually awake before they resist the LMA. Incidences of coughing, choking and holding of breath during the waking phase are reduced. Inserting and removing the LMA have a minimum effect on cardiovascular reactions and intra-ocular pressure. Barotrauma is not common with an LMA. The biggest disadvantage of the LMA compared to the endotracheal tube is that the LMA does not provide any protection against aspiration.

8. Abbreviations

2.3 DPG	diphosphoglycerate
ALICE	automatic lung inflation control effect
APL	adjustable pressure limitation
ARDS	adult respiratory distress syndrome
ASB	assisted spontaneous breathing
BPD	bronchopulmonary dysplasia
C	compliance
CO	carbon monoxide
CO₂	carbon dioxide
CPAP	continuously applied airway pressure
C_{Pat}	patient compliance
DGAI	German Association of Anesthesiology and Intensive Care
E	expiration
ECC	extracorporeal circulation
ECG	electrocardiography
ECV	extracellular volume
EEG	electroencephalography
EPR	expiration prolonging reflex
ERV	expiratory reserve volume
etCO₂	end-tidal carbon dioxide
ETT	endotracheal tube
FiO₂	fraction of inspired concentration of oxygen
FOB	fiberoptic bronchoscope
FRC	functional residual capacity
H₂O	water
HbF	fetal hemoglobin
HbA	adult hemoglobin
HME	heat and moisture exchangers
HR	heart rate
I	inspiration
iBP	invasive blood pressure
IC	inspiratory capacity
iCO₂	inspiratory concentration of carbon dioxide
ICV	intracellular volume

ID	inside diameter
I:E	ratio of inspiratory time to expiratory time
IIR	inspiration inhibiting reflex
IMV	intermittent mandatory ventilation
IPPV	intermittent positive pressure ventilation
IRV	inspiratory reserve volume
i.v.	intravenous
kg	kilogram
l	liter
LMA	laryngeal mask
MAC	minimal alveolar concentration
MAP	mean arterial pressure
min	minute
ml	milliliter
mmHg	millimeters of mercury
MV	minute volume
N ₂ O	nitrous oxide
NB	newborn
NiBP	non-invasive blood pressure
O ₂	oxygen
OD	outside diameter
p _a CO ₂	partial pressure of carbon dioxide in the arterial blood
p _a O ₂	partial pressure of oxygen in the arterial blood
P _{AW}	airway pressure
PCV	pressure-controlled ventilation
PEEP	positive end-expiratory pressure
pH	a measure of the concentration of hydrogen ions in a substance or solution, which denotes the degree to which the substance is acidic or alkaline (basic)
PIP	peak inspiratory pressure

P_{MAX}	maximum pressure limit
P_{PCV}	pressure limit
P_{PLAT}	plateau pressure
RDS	respiratory distress syndrome
RV	residual volume
SIMV	synchronized intermittent mandatory ventilation
s/sec	second
SpO_2	oxygen saturation of arterial blood as determined by pulse oximetry
TC	total capacity
Ti:Te	ratio of inspiratory time to expiratory time
Tip:Ti	ratio of inspiratory pause time to inspiratory time
TIVA	total intravenous anesthesia
VC	vital capacity
VCV	volume-controlled and time-cycled ventilation
V_{PAT}	patient volume
V_T	tidal volume
WP	week of pregnancy

9. Index

ALICE 21, 104, 166
alveolar ventilation 21, 73, 76, 169, 172
Ambu-Paedi System 86
anesthetic agent 44, 46-48, 132, 137
anesthetic agent measuring 108, 127
anesthetic agent uptake 102, 109, 130
Ayre T-piece 85, 131
Bain System 79, 84, 85
balance of water 89
blood pressure 30, 100, 115, 116, 131
blood volume 30
body temperature 24, 32, 34
breathing gas conditioning 113, 135, 142, 148
breathing gas humidifier 144-146, 148
capnography 98, 120-123, 130, 131
Cato 85, 92, 94, 99, 106, 131, 133
Cicero EM 85, 92, 94, 99, 106, 131, 133, 134
closing volume 20, 75
complete rebreathing system (closed system) 89
compliance 16, 17-18, 61, 67, 68, 73, 76, 91, 97
compliance compensation 91, 96, 97, 106, 133
dead space volume 19, 54, 79, 98, 122, 177, 182
desflurane 39, 40, 43, 44
Disoprivan 49
ductus botalli 27, 28
electrocardiography (ECG) 100, 108, 118, 119, 131
electrolyte 35
enflurane 38, 39, 42, 44
extrapulmonary oxygen toxicity 26, 110
FiO₂ 74, 77, 108, 131
foramen ovale 27, 28
fresh-gas decoupler 93, 94, 95, 106, 133
functional residual capacity (FRC) 20, 23, 75, 162
halothane 32, 39, 40, 41, 44, 118

heart 27, **29**, 75, 118
heart rate **29**,32,118,119
heatable hoses 149, 180-182
heat and moisture exchanger (HME) **146-148**, 150, 182
hemoglobin **31**, 111, 112
hypoxia 15, 24, 27, 112
I:E ratio 74
inspiratory flow 61, 67, 72, **76**, 92, 106
intermittent mandatory ventilation (IMV) 165
intermittent positive pressure ventilation (IPPV) 91, 106, 168, 169
intravenous anesthesia 49
isoflurane 32, 38, 39, **42**, 44
Jackson-Rees 79, **81**
Julian 85, 92, 94, **99**, 106, 127, 131, 133
Kuhn System 79, **82**, 85, 89, 130
laryngeal mask (LMA) 54, **185-192**
leakage 55, 64, 91, 96, 104, 106, 133
low-flow anesthesia **132-135**, 137
malignant hypothermia 50, 51, 105, **120**
manual ventilation 85, **90-91**
mask 54, 89, 98
measuring body temperature 113
measuring FiO₂ 128
mechanical ventilation **61**, 90
mechanics of ventilation 17
minimal alveolar concentration (MAC) 39, 127
minute volume (MV) 74, 87, 94, 120, 122
muscle relaxant 51
nitrous oxide 40, 41
non-rebreathing system **78**, 79, 85, 86, 88, 123, 130
oxygen-binding curve 110-112
oxygen consumption **24**, 32, 113

- oxygen toxicity 26
- oxygen uptake 129
- partial rebreathing system** 87
- PhysioFlex 89, 92, **102-106**, 109, 129, 130
- positive end-expiratory pressure (PEEP) 21, 67, **75**, 92, 104, 167, 170
- pressure-controlled ventilation (PCV) **64-72**, 77, 106, 133, 149, 168, 178, 179
- pressure limit 76, 77
- Propofol 49
- pulmonary volume 19
- pulse oximetry 26, 108, **110-112**
- rebreathing system** 87-88, 130
- regulating body temperature 32
- resistance 22, 61
- respiratory rate **21-22**, 73, 77, 89, 93, 98, 106, 123
- respiratory resistance 22
- retinopathy of prematurity 26, 110
- sevoflurane** 39, 40, **42**, 44, 46
- soda lime **45-48**, 120
- stethoscope 108, **109**, 130
- surfactant 18, **23**, 161, 169
- synchronized intermittent mandatory ventilation (SIMV) **63**, 106
- tidal volume** 19, 22, 67, **73**, 94, 96, 146, 179
- time constant 137
- total intravenous anesthesia (TIVA) 50
- tube **55-57**, 134
- ventilation control** 15
- ventilation parameter 73
- volumetry 108, **126**, 131
- xenon** 43

HEADQUARTERS

Drägerwerk AG & Co. KGaA
Moislinger Allee 53–55
23558 Lübeck, Germany

www.draeger.com

REGION EUROPE CENTRAL AND EUROPE NORTH

Dräger Medical GmbH
Moislinger Allee 53–55
23558 Lübeck, Germany
Tel +49 451 882 0
Fax +49 451 882 2080
info@draeger.com

REGION EUROPE SOUTH

Dräger Médical S.A.S.
Parc de Haute Technologie d'Antony 2
25, rue Georges Besse
92182 Antony Cedex, France
Tel +33 1 46 11 56 00
Fax +33 1 40 96 97 20
dlmfr-contact@draeger.com

REGION MIDDLE EAST, AFRICA, CENTRAL AND SOUTH AMERICA

Dräger Medical GmbH
Branch Office Dubai
Dubai Healthcare City
P.O. Box 505108
Dubai, United Arab Emirates
Tel + 971 436 24 762
Fax + 971 436 24 761
contactuae@draeger.com

REGION ASIA / PACIFIC

Draeger Medical South East Asia Pte Ltd
25 International Business Park
#04-27/29 German Centre
Singapore 609916, Singapore
Tel +65 6572 4388
Fax +65 6572 4399
asia.pacific@draeger.com

REGION NORTH AMERICA

Draeger Medical, Inc.
3135 Quarry Road
Telford, PA 18969-1042, USA
Tel +1 215 721 5400
Toll-free +1 800 437 2437
Fax +1 215 723 5935
info.usa@draeger.com